



# PARTS CATALOGUE



DPBMC



VOM2

## YZF250-A ( BFA1 ) MALAYSIA R25

YZF250-A  
PARTS CATALOGUE  
©2022 by Yamaha Motor Co., Ltd.  
1st edition, September 2022  
All rights reserved.  
Any reprinting or unauthorized use  
without the written permission of  
Yamaha Motor Co., Ltd.  
is expressly prohibited.  
Printed in Japan.

# FOREWORD

This Parts Catalogue is related to the parts for the model(s) on the cover page. When you are ordering replacement parts, please refer to this Parts Catalogue and quote both part numbers and part names correctly.

1. Modifications or additions which have been made after the issue of the Parts Catalogue will be announced in the Parts News.  
It is advisable that you make the necessary corrections to the Parts Catalogue according to the Parts News.
2. Abbreviations  
The following abbreviations are used in this Parts Catalogue.  
“UR” Use specified parts number.  
“UN” Use as many as needed.  
“AP” Alternate Parts  
“LM” Locally Made (Parts need to be ordered locally)  
“F#” Frame No. (Applicable machine No.)  
“O/S” Over Size
3. The number of components for assembly
  - Parts, which are to be supplied in an assembly, are listed with a dot (.) in front of the part name as shown below.
  - The numeral appearing to the right of each component part indicates the quantity of parts for each assembly unit.

PART NO.	DESCRIPTION	Q'TY	REMARKS
2F5-83310-60	FRONT FLASHER LIGHT ASSY	2	
115-83311-60	.BULB (6V-18W)	1	

4. Applicable colours of graphics are represented in the “REMARKS” as shown below.

PART NO.	DESCRIPTION	Q'TY	REMARKS
2N4-24110-00-X5	FUEL TANK COMP.	2	MXR
3J1-24240-10	.GRAPHIC, FUEL TANK	1	FOR MXR

5. Note that the illustrations for reference in finding parts numbers are not to be used for assembling. When assembling, please use the applicable service manual.

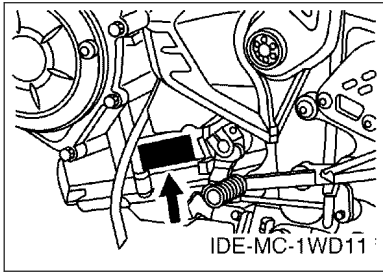
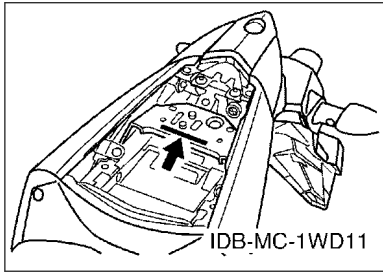
6. The asterisk (\*) before a reference number indicates modified items after the first edition.

# FOREWORD

7. Applicable Serial No.

Frame Serial No.

Engine Serial No.



8. Applicable Colour Code (The (\*) mark shows Model colour.)

Abbreviation	Colour Name	Colour Code
DPBM15	DEEP PURPLISH BLUE METALLIC 15	1329
DPBMC(*)	DEEP PURPLISH BLUE METALLIC C	0564
LGB	LOW GLOSS BLACK	0098
MBM3	MAT BLUE METALLIC 3	0960
MNM3	MAT GRAY METALLIC 3	1278
VOM2(*)	VIVID ORANGE METALLIC 2	0552

9. Applicable Starting Serial No.

Frame Serial No.

Serial No.	Name Of Q'ty Column	Model Code

Engine Serial No.

Serial No.	Name Of Q'ty Column	Model Code

VOM2

# CONTENTS

## ENGINE

CYLINDER HEAD.....	1
CRANKSHAFT & PISTON.....	3
VALVE.....	5
CAMSHAFT & CHAIN.....	7
WATER PUMP.....	8
RADIATOR & HOSE.....	9
OIL PUMP.....	10
INTAKE.....	11
EXHAUST.....	13
CRANKCASE.....	14
CRANKCASE COVER 1.....	15
STARTER CLUTCH.....	16
CLUTCH.....	17
TRANSMISSION.....	18
SHIFT CAM & FORK.....	20
SHIFT SHAFT.....	21

## CHASSIS

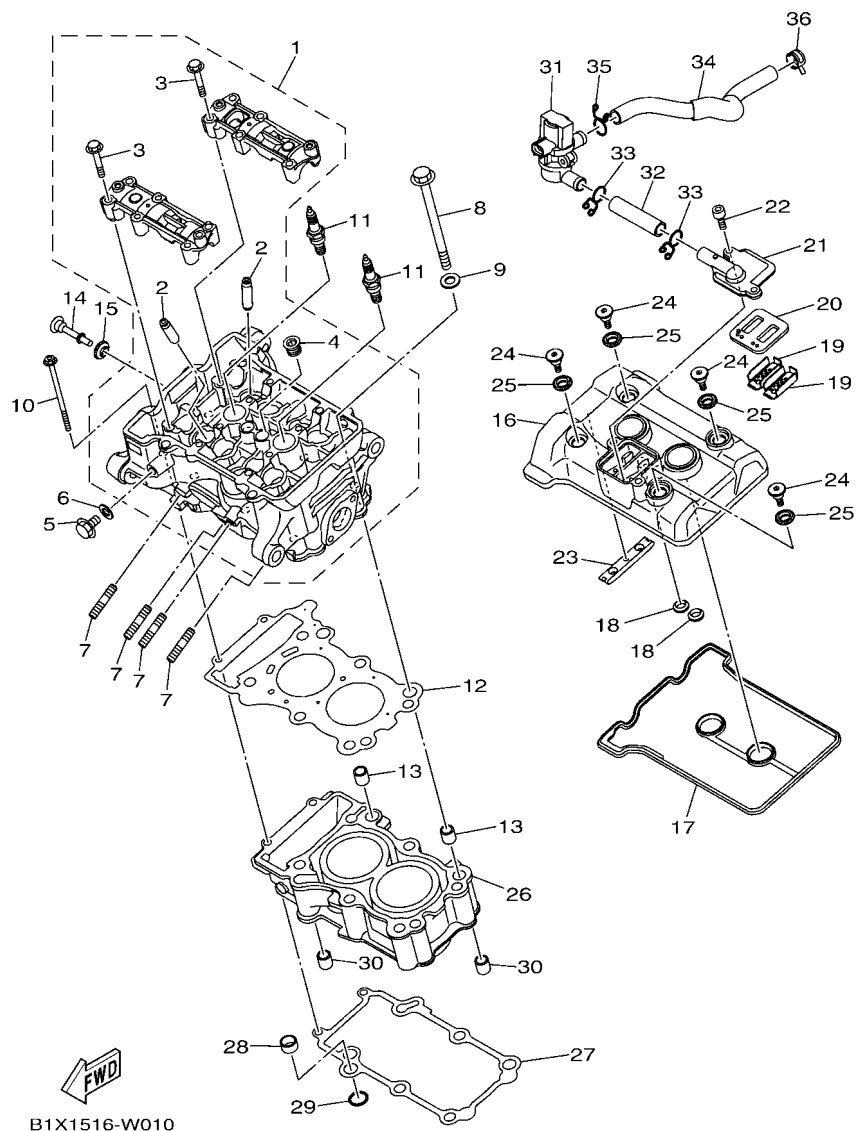
FRAME.....	22
FENDER.....	24
SIDE COVER.....	26
REAR ARM & SUSPENSION.....	28
STEERING.....	29
FRONT FORK.....	30
FUEL TANK.....	32
SEAT.....	35
FRONT WHEEL.....	36
FRONT BRAKE CALIPER.....	37
REAR WHEEL.....	38
REAR BRAKE CALIPER.....	40
STEERING HANDLE & CABLE.....	41
FRONT MASTER CYLINDER.....	42
STAND & FOOTREST.....	44
REAR MASTER CYLINDER.....	46
WINDSHIELD.....	48
COWLING 1.....	50
GENERATOR.....	53
STARTING MOTOR.....	54
FLASHER LIGHT.....	55

METER.....	56
HEADLIGHT.....	57
TAILLIGHT.....	58
HANDLE SWITCH & LEVER.....	59
ELECTRICAL 1.....	60
ELECTRICAL 2.....	62
ELECTRICAL 3.....	64

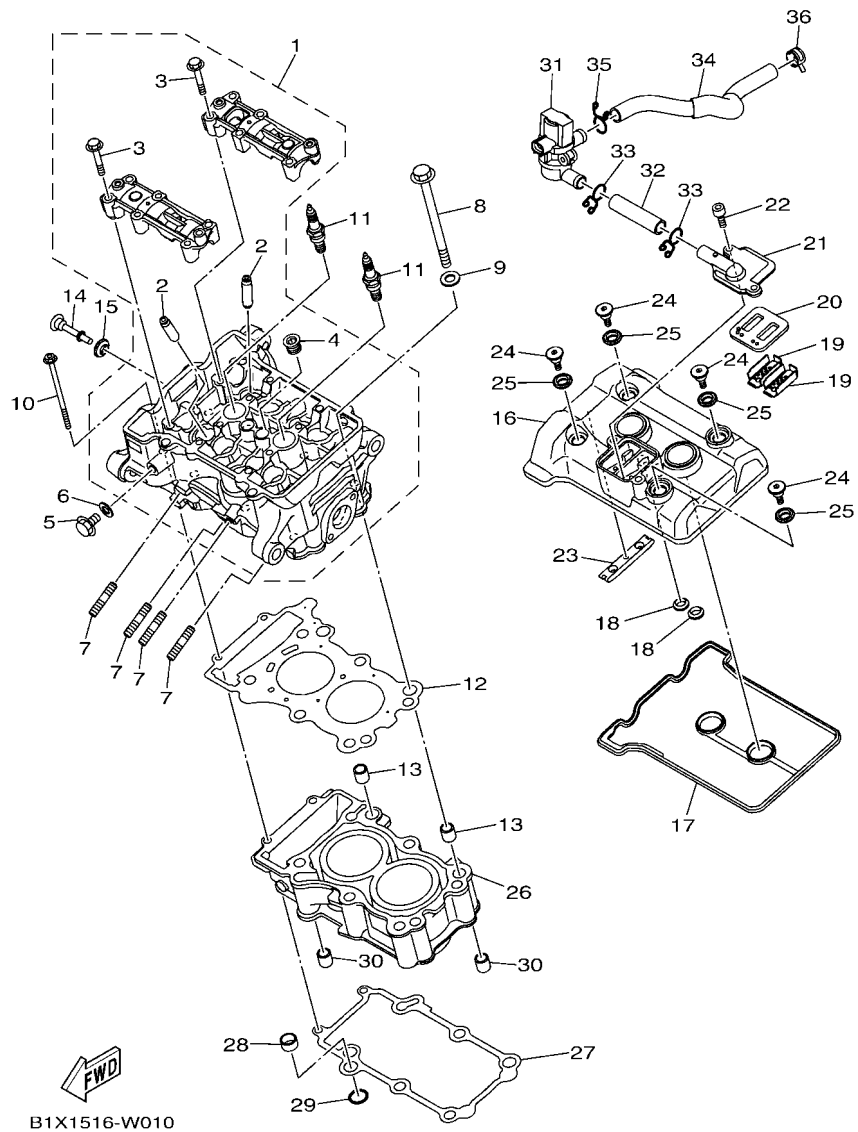
## INDEX

NUMERICAL INDEX.....	65
----------------------	----

**FIG. 1 CYLINDER HEAD**



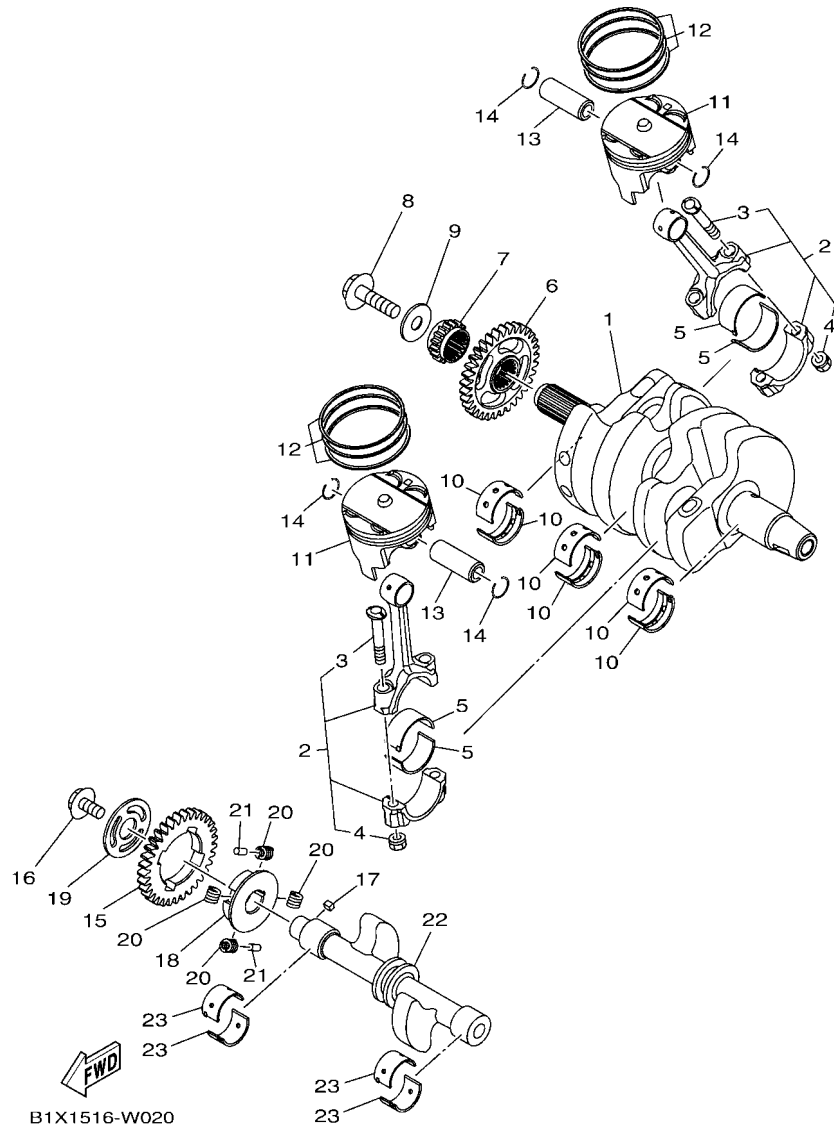
REF. NO.	PART NO.	DESCRIPTION	BFA1				REMARKS
1	B1X-E1102-01	CYLINDER HEAD ASSY	1				
2	1WD-E1133-10	.GUIDE, VALVE 1	8				
3	90105-06027	.BOLT, FLANGE	12				
4	90340-18002	.PLUG, STRAIGHT SCREW	1				
5	95022-08012	BOLT, FLANGE	1				
6	90430-08119	GASKET	1				
7	95612-08625	BOLT, STUD	4				
8	1WD-E1361-00	BOLT, CYLINDER HOLDING 1	6				
9	90201-10845	WASHER, PLATE	6				
10	90110-06870	BOLT, HEXAGON SOCKET HEAD	2				
11	94700-00436	PLUG, SPARK (NGK LMAR8A-9)	2				
12	BS8-E1181-00	GASKET, CYLINDER HEAD 1	1				
13	99530-14016	PIN, DOWEL	2				
14	90109-06898	BOLT	1				
15	1WD-E111G-00	RUBBER, MOUNT 1	1				
16	B1X-E1191-00	COVER, CYLINDER HEAD 1	1				
17	B1X-E1193-00	GASKET, HEAD COVER 1	1				
18	B1X-E1195-00	GASKET	2				
19	5VY-1482K-00	PLATE	2				
20	1WD-E4890-00	REED VALVE ASSY	1				
21	1WD-E4899-00	CAP, CASE	1				
22	91332-06020	BOLT	2				
23	1WD-E2241-01	GUIDE, STOPPER 2	1				
24	90109-06899	BOLT	4				
25	1WD-E111G-00	RUBBER, MOUNT 1	4				
26	1WD-E1311-10	CYLINDER 1	1				
27	B1X-E1351-00	GASKET, CYLINDER	1				



**FIG. 1 CYLINDER HEAD**

REF. NO.	PART NO.	DESCRIPTION	BFA1				REMARKS
28	5NL-12564-00	PIPE, WATER	1				
29	93210-16716	O-RING	1				
30	99530-14016	PIN, DOWEL	2				
31	1WD-E4840-10	AIR CUT VALVE ASSY	1				
32	1WD-E4881-00	HOSE, BEND 1	1				
33	90467-16801	CLIP	2				
34	1WD-E4882-02	HOSE, BEND 2	1				
35	90467-16801	CLIP	1				
36	90467-16800	CLIP	1				

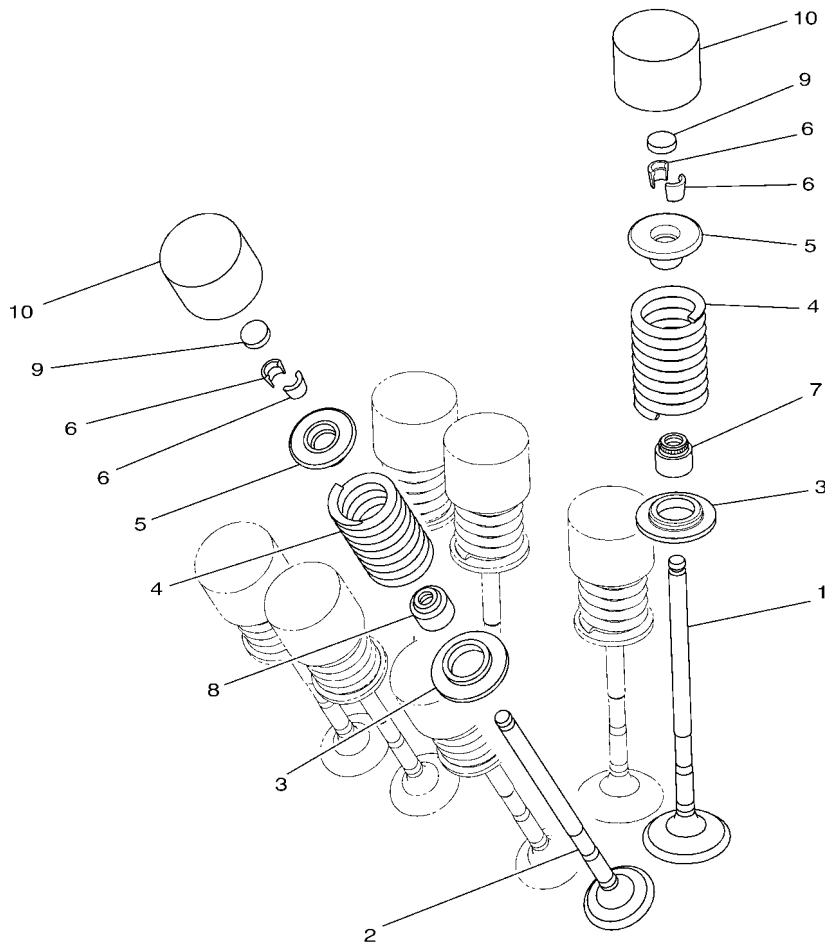
**FIG. 2 CRANKSHAFT & PISTON**



REF. NO.	PART NO.	DESCRIPTION	BFA1			REMARKS
1	1WD-E1411-10	CRANKSHAFT	1			
2	1WD-11650-00	CONNECTING ROD ASSY	2			
3	5SL-11654-00	.BOLT, CONNECTING ROD	2			
4	90179-07652	.NUT	2			
5	1WD-11656-00	PLANE BEARING, CONNECTING ROD	4			UR BLUE
<hr/>						
	1WD-11656-10	PLANE BEARING, CONNECTING ROD	4			UR BLACK
	1WD-11656-20	PLANE BEARING, CONNECTING ROD	4			UR BROWN
	1WD-11656-30	PLANE BEARING, CONNECTING ROD	4			UR GREEN
6	1WD-E1536-00	GEAR, DRIVE	1			
7	1WD-E1549-00	SPROCKET, CAM CHAIN	1			
<hr/>						
8	90105-10883	BOLT, FLANGE	1			
9	90201-10848	WASHER, PLATE	1			
10	B1X-11416-00	PLANE BEARING, CRANKSHAFT 1	6			UR BLUE
	B1X-11416-10	PLANE BEARING, CRANKSHAFT 1	6			UR BLACK
	B1X-11416-20	PLANE BEARING, CRANKSHAFT 1	6			UR BROWN
<hr/>						
	B1X-11416-30	PLANE BEARING, CRANKSHAFT 1	6			UR GREEN
	B1X-11416-40	PLANE BEARING, CRANKSHAFT 1	6			UR YELLOW
11	B1X-E1631-00	PISTON (STD)	2			
12	BS8-E1603-00	PISTON RING SET (STD)	2			
13	1WD-E1633-00	PIN, PISTON	2			
<hr/>						
14	93450-16068	CIRCLIP	4			
15	1WD-E1531-00	GEAR, BALANCE WEIGHT	1			
16	90105-088F8	BOLT, FLANGE	1			
17	90282-04036	KEY, STRAIGHT	1			
18	1WD-E1496-00	BOSS, BUFFER	1			
<hr/>						
19	90201-16812	WASHER, PLATE	1			
20	90501-22800	SPRING, COMPRESSION	4			



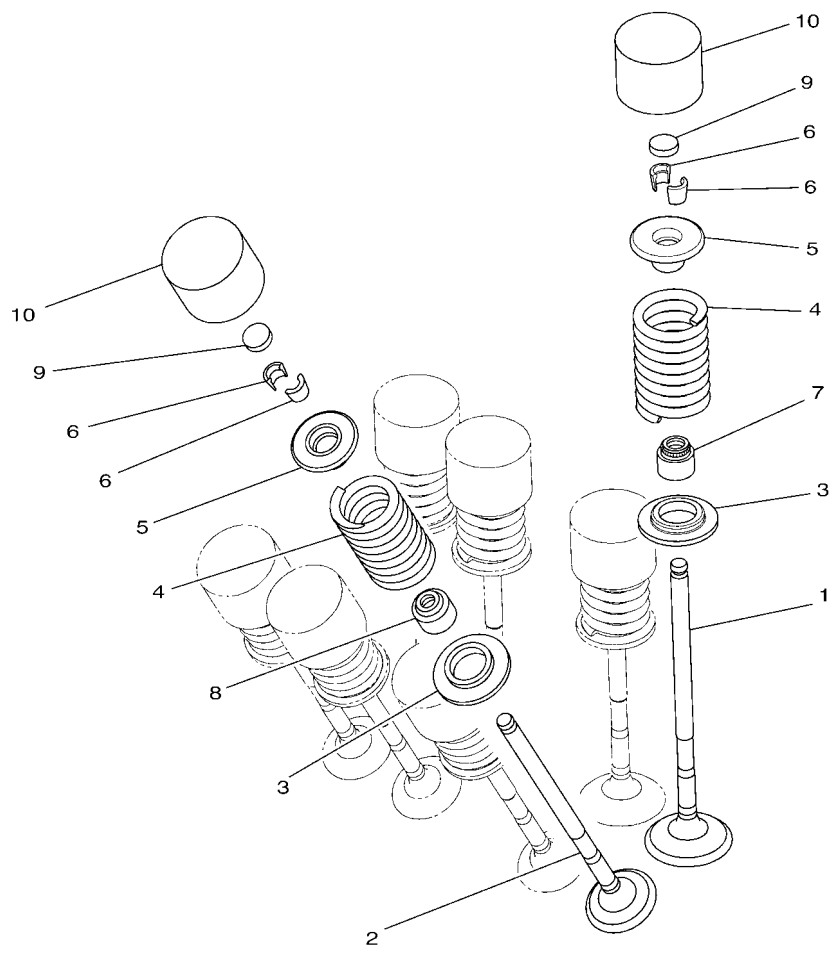




  
B0E1010-T030

**FIG. 3 VALVE**

REF. NO.	PART NO.	DESCRIPTION	BFA1				REMARKS
1	B1X-E2111-00	VALVE, INTAKE	4				
2	B1X-12121-10	VALVE, EXHAUST	4				
3	1WD-E2126-00	SEAT, VALVE SPRING 2	8				
4	B1X-E2113-00	SPRING, VALVE INNER	8				
5	1WD-E2117-00	RETAINER, VALVE SPRING	8				
6	3S0-E2118-00	LOCK, VALVE SPRING RETAINER	16				
7	BS8-E2119-00	SEAL, VALVE STEM	4				
8	1PA-E2119-00	SEAL, VALVE STEM	4				
9	1HX-12168-F0	PAD, ADJUSTING 2 (1.50)	8				UR
	1HX-12168-H1	PAD, ADJUSTING 2 (1.55)	8				UR
	1HX-12168-K1	PAD, ADJUSTING 2 (1.60)	8				UR
	1HX-12168-M1	PAD, ADJUSTING 2 (1.65)	8				UR
	1HX-12168-R1	PAD, ADJUSTING 2 (1.70)	8				UR
	1HX-12168-U1	PAD, ADJUSTING 2 (1.75)	8				UR
	1HX-12168-W1	PAD, ADJUSTING 2 (1.80)	8				UR
	1HX-12168-Y1	PAD, ADJUSTING 2 (1.85)	8				UR
	1HX-12169-11	PAD, ADJUSTING 2 (1.90)	8				UR
	1HX-12169-31	PAD, ADJUSTING 2 (1.95)	8				UR
	1HX-12169-50	PAD, ADJUSTING 2 (2.00)	8				UR
	1HX-12169-70	PAD, ADJUSTING 2 (2.05)	8				UR
	1HX-12169-90	PAD, ADJUSTING 2 (2.10)	8				UR
	1HX-12169-E0	PAD, ADJUSTING 2 (2.15)	8				UR
	1HX-12169-G0	PAD, ADJUSTING 2 (2.20)	8				UR
	1HX-12169-J0	PAD, ADJUSTING 2 (2.25)	8				UR
	1HX-12169-L0	PAD, ADJUSTING 2 (2.30)	8				UR
	1HX-12169-N0	PAD, ADJUSTING 2 (2.35)	8				UR
	1HX-12169-T0	PAD, ADJUSTING 2 (2.40)	8				UR

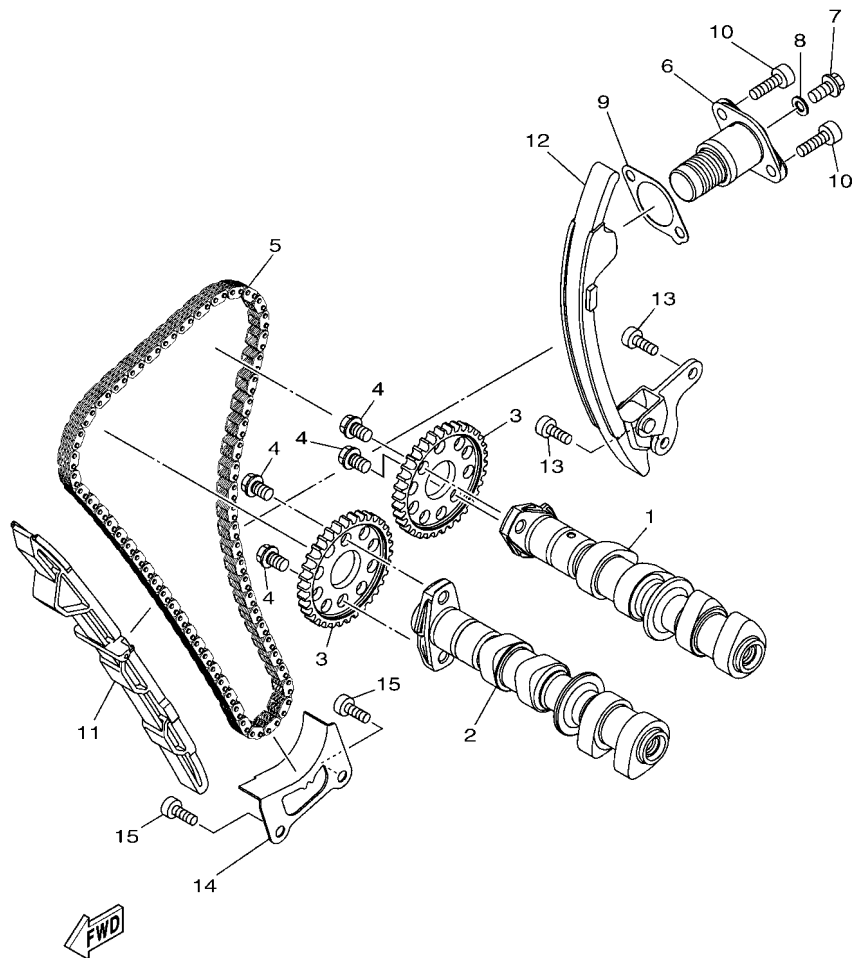


  
 B0E1010-T030

**FIG. 3 VALVE**

REF. NO.	PART NO.	DESCRIPTION	BFA1				REMARKS
10	1WD-E2153-11	LIFTER, VALVE	8				

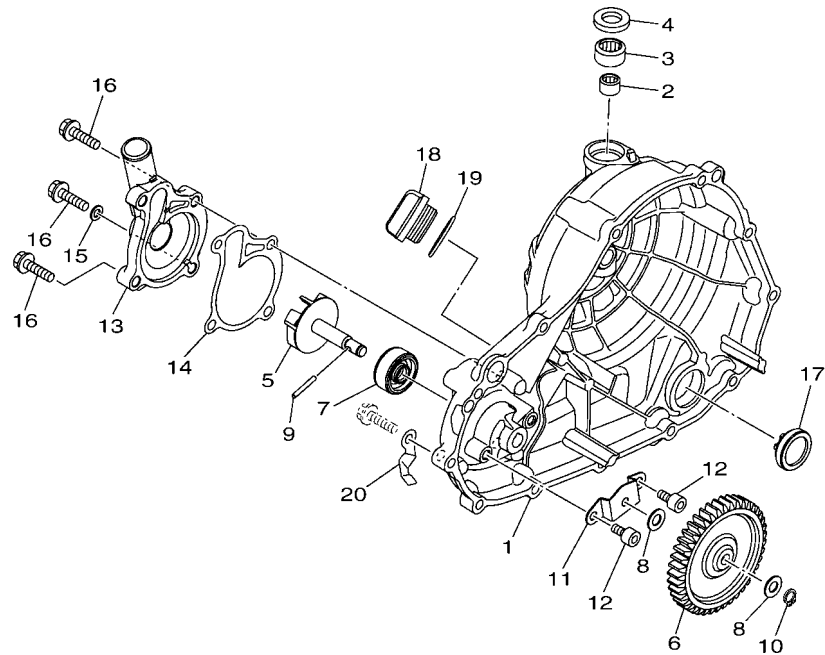
**FIG. 4 CAMSHAFT & CHAIN**



B1X1516-W040

REF. NO.	PART NO.	DESCRIPTION	BFA1				REMARKS
1	B1X-E2170-00	CAMSHAFT ASSY 1	1				
2	B1X-E2180-00	CAMSHAFT ASSY 2	1				
3	1WD-E2176-00	SPROCKET, CAM CHAIN	2				
4	90105-07800	BOLT, FLANGE	4				
5	94568-K0118	CHAIN (98XRH2015-118P-M)	1				
6	B1X-12210-00	TENSIONER ASSY, CAM CHAIN	1				
7	95022-06008	BOLT, FLANGE	1				
8	90430-06014	GASKET	1				
9	1WD-E2213-00	GASKET, TENSIONER CASE	1				
10	95812-06020	BOLT, FLANGE	2				
11	1WD-E2251-00	DAMPER, CHAIN 1	1				
12	1WD-E2252-01	DAMPER, CHAIN 2	1				
13	90110-06161	BOLT, HEXAGON SOCKET HEAD	2				
14	1WD-E2256-00	COVER, CHAIN	1				
15	90110-06161	BOLT, HEXAGON SOCKET HEAD	2				

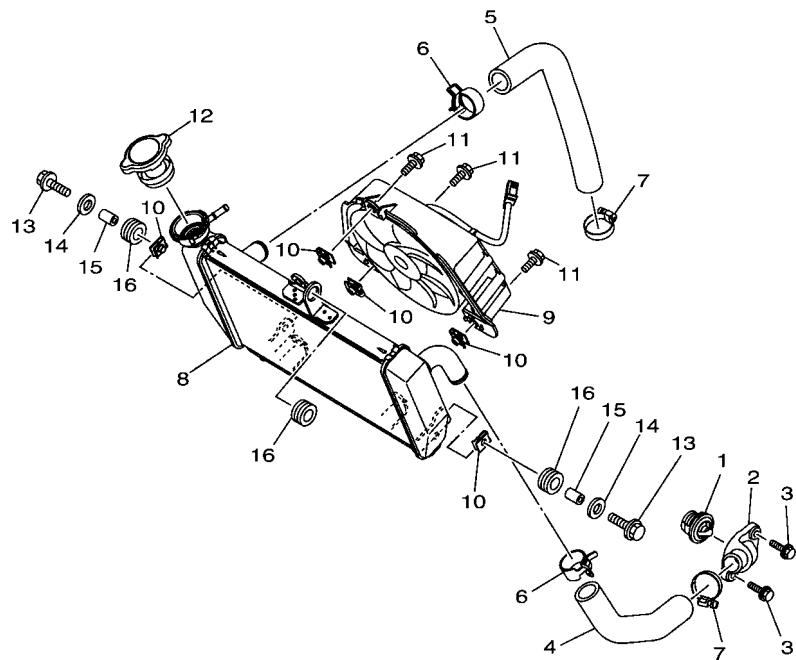
**FIG. 5 WATER PUMP**



REF. NO.	PART NO.	DESCRIPTION	BFA1				REMARKS
1	B1X-E5421-00	COVER, CRANKCASE 2	1				MBL2
2	93317-11096	BEARING	1				
3	93315-21570	BEARING	1				
4	93102-15801	OIL SEAL	1				
5	1WD-E2450-00	IMPELLER SHAFT ASSY	1				
6	1WD-E2453-00	GEAR	1				
7	33S-E2223-00	SEAL	1				
8	33S-E2456-00	WASHER	2				
9	1WD-E319L-00	PIN, STRAIGHT	1				
10	99009-08400	CIRCLIP	1				
11	1WD-E2681-00	PLATE	1				
12	91312-06010	BOLT, HEXAGON SOCKET HEAD	2				
13	1WD-E2422-00	COVER, HOUSING	1				
14	1WD-E2428-00	GASKET, HOUSING COVER 2	1				
15	90430-06014	GASKET	1				
16	95022-06025	BOLT, FLANGE	3				
17	2H7-15361-00	GAUGE, LEVEL	1				
18	1WD-E5362-00	PLUG, OIL LEVEL	1				
19	93210-27807	O-RING	1				
20	90462-08225	CLAMP	1				

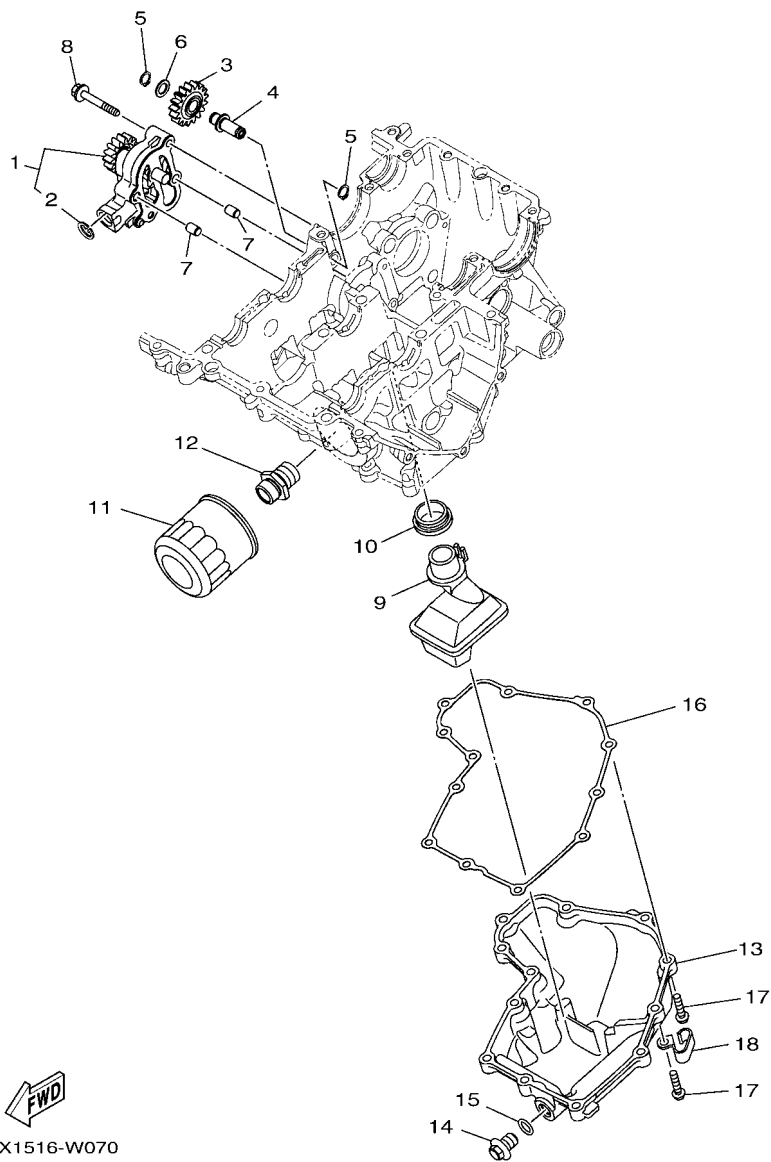
  
B1X4516-X050

**FIG. 6 RADIATOR & HOSE**



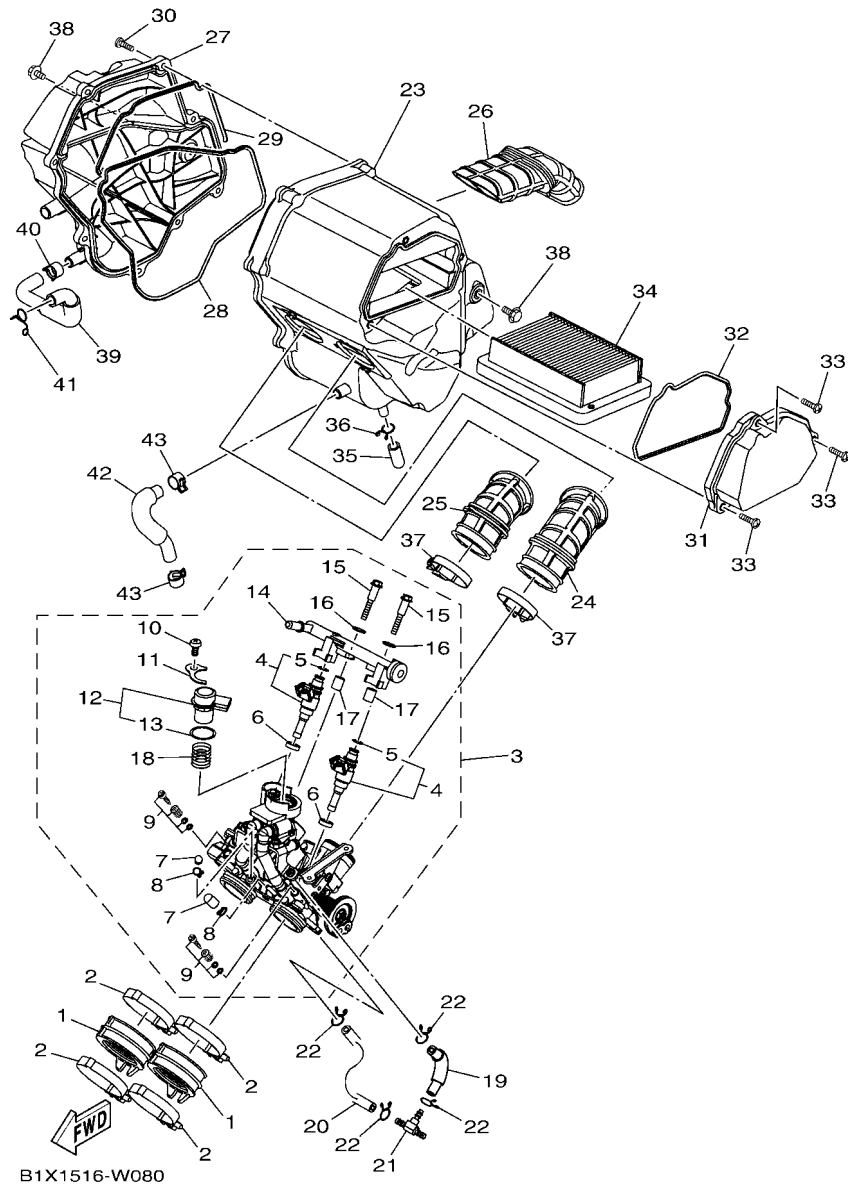
REF. NO.	PART NO.	DESCRIPTION	BFA1				REMARKS
1	5P0-12411-01	THERMOSTAT	1				
2	1WD-E2413-00	COVER, THERMOSTAT	1				
3	95022-06020	BOLT, FLANGE	2				
4	1WD-E2577-00	HOSE 2	1				
5	1WD-E2578-00	HOSE 3	1				
6	90467-250A1	CLIP	2				
7	90450-28001	HOSE CLAMP ASSY	2				
8	1WD-E2461-00	RADIATOR COMP	1				
9	1WD-E2405-00	BLOWER ASSY	1				
10	1WD-E2671-00	NUT 1	5				
11	5YP-E2675-00	BOLT, BLOWER HOLDING	3				
12	5ST-E2462-00	CAP, RADIATOR	1				
13	95827-06025	BOLT, FLANGE	2				
14	90201-06072	WASHER, PLATE	2				
15	90387-064W3	COLLAR	2				
16	90480-15808	GROMMET	3				

**FIG. 7 OIL PUMP**



B1X1516-W070

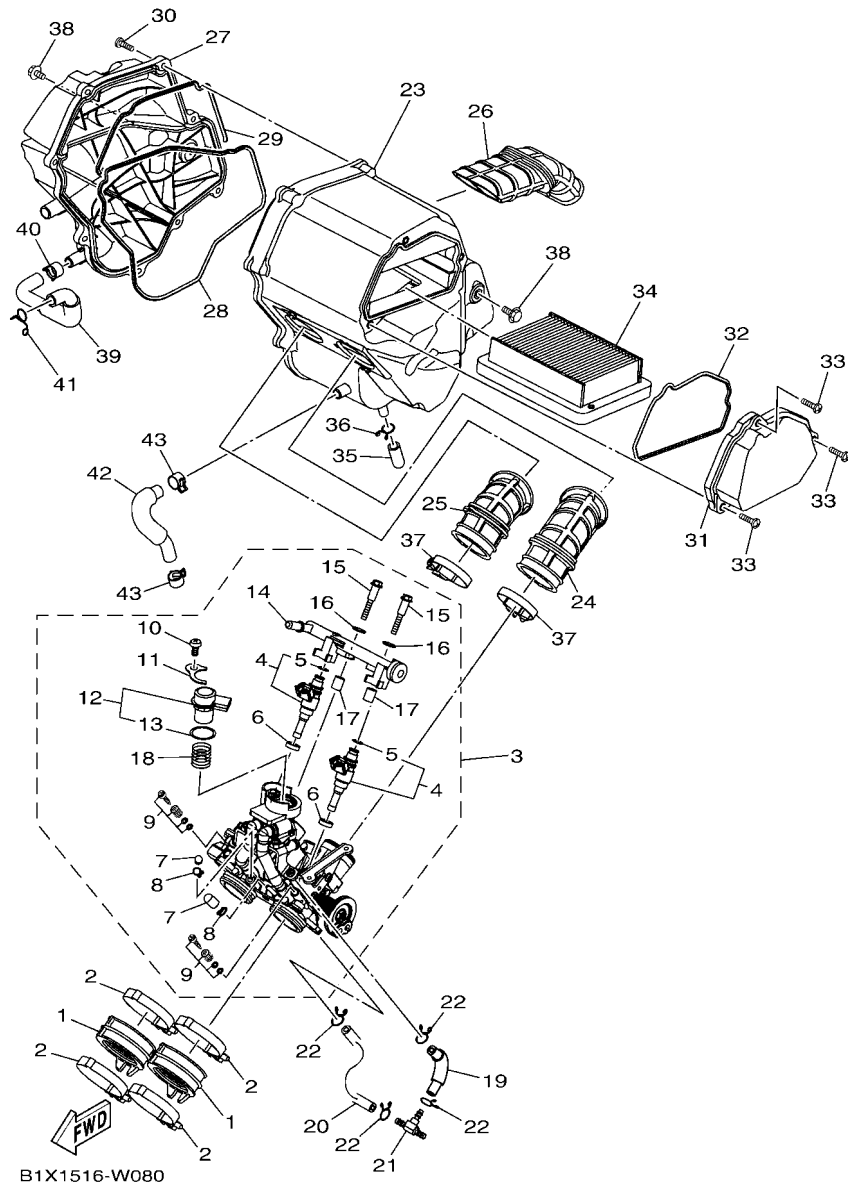
REF. NO.	PART NO.	DESCRIPTION	BFA1				REMARKS
1	B1X-E3300-00	OIL PUMP ASSY	1				
2	99009-15500	.CIRCLIP	1				
3	1WD-E3341-00	GEAR, OIL PUMP IDLE	1				
4	1WD-E3342-00	SHAFT, IDLE GEAR	1				
5	99009-10400	CIRCLIP	2				
6	90201-10119	WASHER, PLATE	1				
7	99530-08012	PIN, DOWEL	2				
8	90105-06027	BOLT, FLANGE	4				
9	1WD-E3410-00	STRAINER HOUSING ASSY	1				
10	1WD-E3415-00	SEAL, OIL STRAINER	1				
11	1WD-E3440-10	ELEMENT ASSY, OIL CLEANER	1				
12	90401-20011	BOLT, UNION	1				
13	B1X-E3417-01	COVER, STRAINER	1				
14	90340-12808	PLUG, STRAIGHT SCREW	1				
15	4YS-E1198-00	GASKET	1				
16	B1X-E3414-00	GASKET, STRAINER COVER	1				
17	95022-06025	BOLT, FLANGE	12				
18	90462-08810	CLAMP	1				



**FIG. 8 INTAKE**

REF. NO.	PART NO.	DESCRIPTION	BFA1				REMARKS
1	B1X-E3635-00	JOINT, INTAKE 1	2				
2	90450-52801	HOSE CLAMP ASSY	4				
3	B1X-E3750-01	THROTTLE BODY ASSY	1				
4	1WD-E3761-00	.INJECTOR	2				
5	5PS-14147-00	.O-RING	1				
6	1WD-E3556-00	.GASKET, MANIFOLD	2				
7	895-14169-00	.CAP	2				
8	8A7-14139-00	.CLIP, PIPE	2				
9	5JW-14104-00	.AIR SCREW SET	2				
10	98502-06012	.SCREW, PAN HEAD	1				
11	1WD-E4243-00	.PLATE	1				
12	1WS-85801-01	.STEPPING MOTOR	1				
13	54P-E416A-00	.O-RING	1				
14	1WD-E3938-00	.PIPE	1				
15	1WD-E3573-00	.BOLT 1	2				
16	8GL-13571-00	.WASHER	2				
17	8HG-14534-00	.COLLAR	2				
18	1WS-14335-00	.SPRING, PLUNGER	1				
19	B1X-E4465-00	PIPE	1				
20	2MS-E4466-00	PIPE	1				
21	90413-06031	WAY 3	1				
22	90467-09006	CLIP	4				
23	BR5-E4411-00	CASE, AIR CLEANER 1	1				
24	B1X-E4469-00	FUNNEL, AIR	1				
25	B1X-E446C-00	FUNNEL 2	1				
26	BR5-E4437-00	DUCT	1				
27	B1X-E4412-00	CAP, CLEANER CASE 1	1				

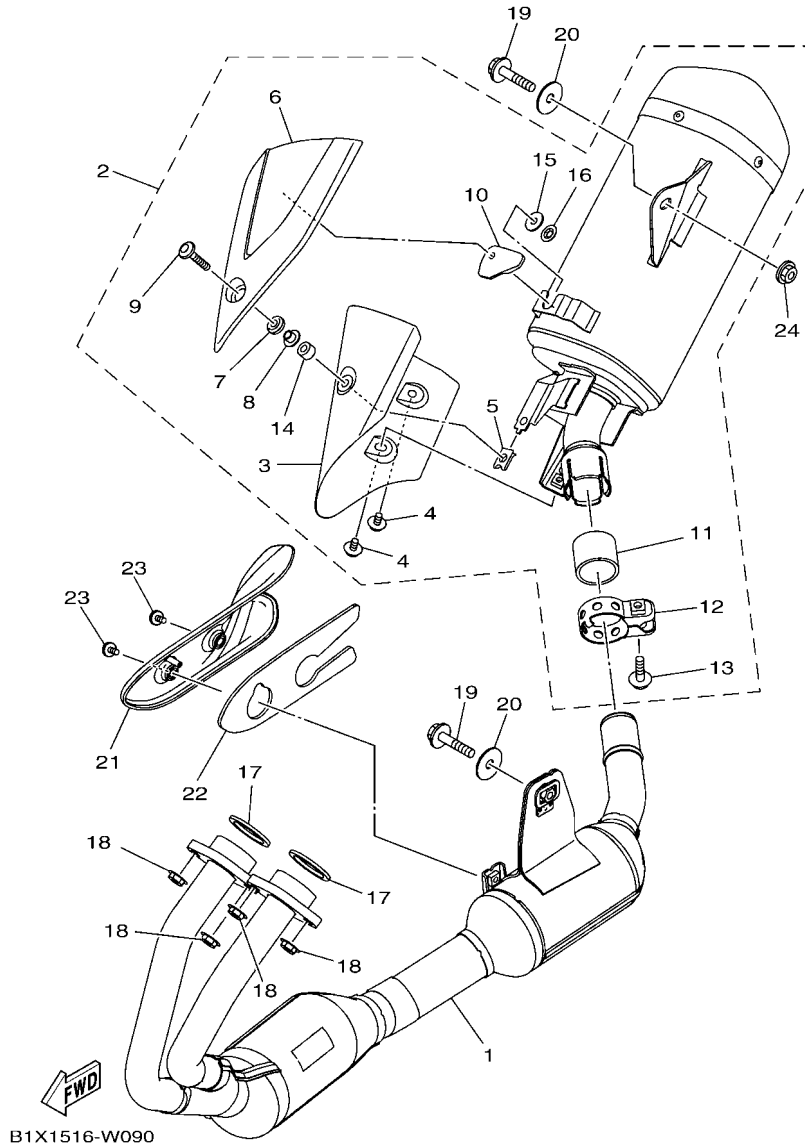




**FIG. 8 INTAKE**

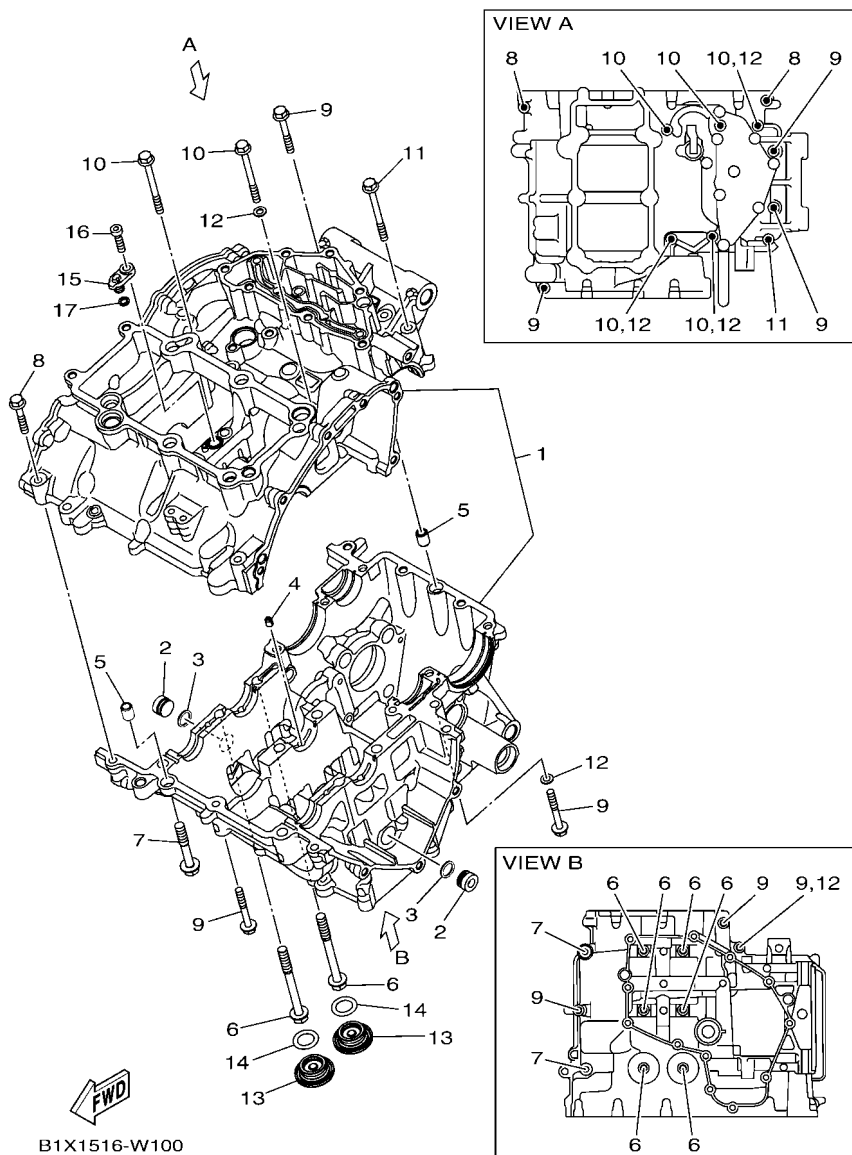
REF. NO.	PART NO.	DESCRIPTION	BFA1				REMARKS
28	1WD-E4452-00	SEAL	1				
29	1WD-E4457-00	SEAL	1				
30	97702-50025	SCREW, TAPPING	8				
31	1WD-E4422-00	CAP, CLEANER CASE 2	1				
32	1WD-E4462-00	SEAL	1				
<hr/>							
33	98902-05020	SCREW, BIND	3				
34	1WD-E4451-00	ELEMENT, AIR CLEANER	1				
35	52B-E443E-00	PIPE, DRAIN	1				
36	90467-110A3	CLIP	1				
37	54P-E3474-00	BAND	2				
<hr/>							
38	95D32-06010	BOLT, FLANGE DEEP RECESS	2				
39	B1X-E3543-00	HOSE, AIR	1				
40	90467-13802	CLIP	1				
41	90467-12052	CLIP	1				
42	2MS-E5373-02	PIPE, BREATHER	1				
<hr/>							
43	90467-13802	CLIP	2				
<hr/>							
<hr/>							
<hr/>							
<hr/>							

**FIG. 9 EXHAUST**



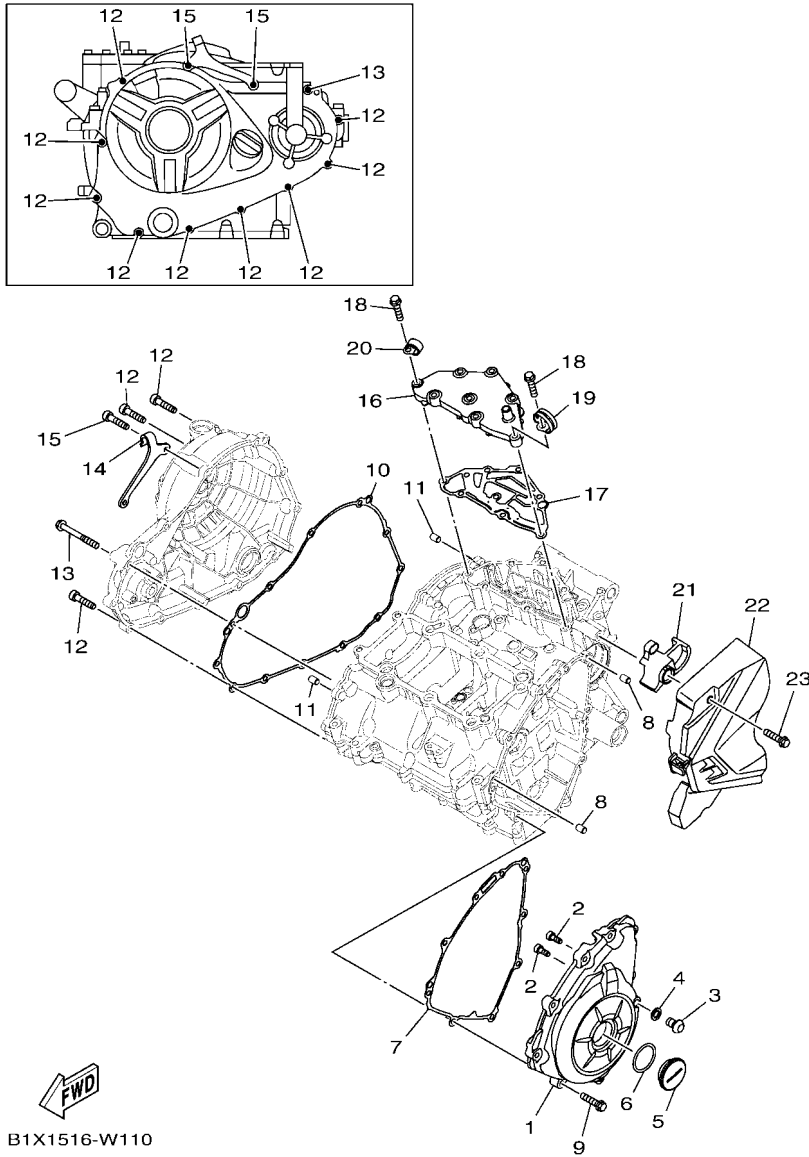
REF. NO.	PART NO.	DESCRIPTION	BFA1				REMARKS
1	B1X-E4602-00	EXHAUST PIPE COMP.	1				
2	BR5-E4710-00	MUFFLER ASSY 1	1				
3	1WD-E4758-00	.PROTECTOR, SILENCER	1				
4	90111-06802	.BOLT, HEXAGON SOCKET BUTTON	2				
5	90183-06818	.NUT, SPRING	1				
6	1WD-E4728-00	.PROTECTOR, MUFFLER 2	1				
7	90480-12581	.GROMMET	1				
8	90387-06273	.COLLAR	1				
9	90111-06847	.BOLT, HEXAGON SOCKET BUTTON	1				
10	1WD-E4763-00	.SPACER	1				
11	54D-E4714-00	.GASKET, MUFFLER	1				
12	1WD-E4715-00	.BAND, MUFFLER	1				
13	95027-08035	.BOLT, FLANGE	1				
14	90387-068N4	.COLLAR	1				
15	90201-06088	.WASHER, PLATE	1				
16	90183-06011	.NUT, SPRING	1				
17	1WD-E4613-00	GASKET, EXHAUST PIPE	2				
18	95707-08500	NUT, FLANGE	4				
19	90105-088G7	BOLT, FLANGE	2				
20	90201-08612	WASHER, PLATE	2				
21	B1X-E4628-00	PROTECTOR, EXHAUST PIPE	1				
22	B1X-E475P-00	SEAT	1				
23	90111-06860	BOLT, HEXAGON SOCKET BUTTON	2				
24	95607-08200	NUT, SELF-LOCKING	1				

**FIG. 10 CRANKCASE**



B1X1516-W100

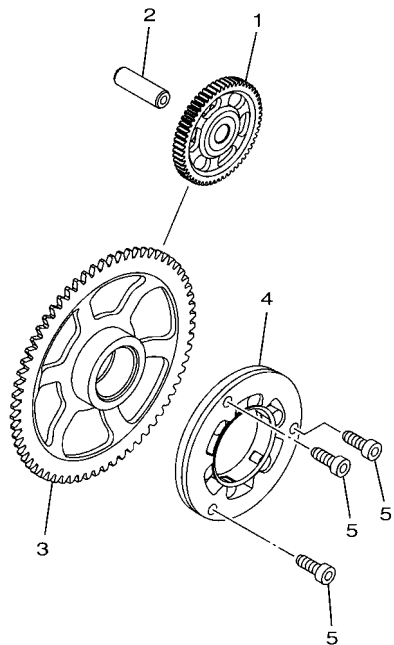
REF. NO.	PART NO.	DESCRIPTION	BFA1			REMARKS
1	B1X-E5150-00	CRANKCASE ASSY	1			MBL2
2	90338-16262	PLUG	2			
3	93210-12803	O-RING	2			
4	1WD-E5148-00	NOZZLE 2	1			
5	99530-10014	PIN, DOWEL	2			
6	90105-088F7	BOLT, FLANGE	6			
7	90105-088G0	BOLT, FLANGE	2			
8	95812-06035	BOLT, FLANGE	2			
9	95812-06045	BOLT, FLANGE	6			
10	95812-06065	BOLT, FLANGE	5			
11	95812-08070	BOLT, FLANGE	1			
12	90430-06014	GASKET	4			
13	90340-27008	PLUG, STRAIGHT SCREW	2			
14	93210-32172	O-RING	2			
15	B1X-E5155-00	NOZZLE 3	1			
16	90110-06161	BOLT, HEXAGON SOCKET HEAD	1			
17	93210-068F7	O-RING	1			



**FIG. 11 CRANKCASE COVER 1**

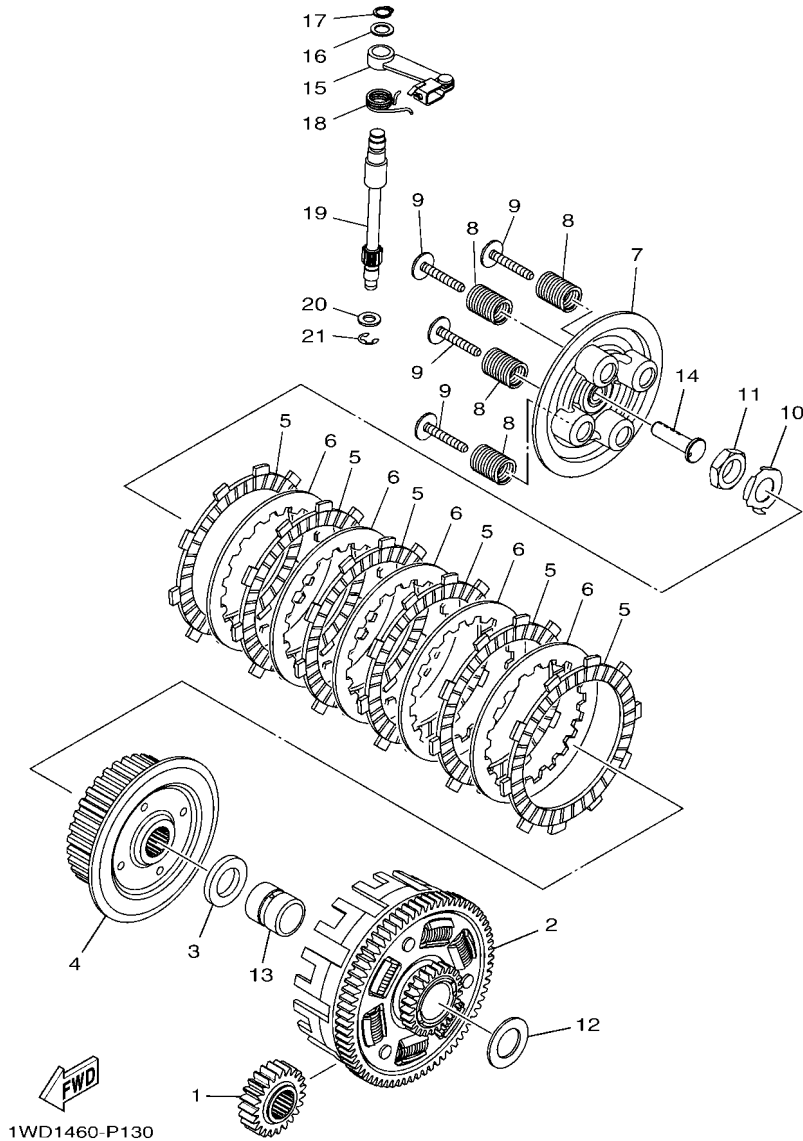
REF. NO.	PART NO.	DESCRIPTION	BFA1				REMARKS
1	1WD-E5411-00	COVER, CRANKCASE 1	1				MBL2
2	90110-05032	BOLT, HEXAGON SOCKET HEAD	2				
3	92014-08012	BOLT, BUTTON HEAD	1				
4	90430-08143	GASKET	1				
5	90340-32819	PLUG, STRAIGHT SCREW	1				
6	93210-32816	O-RING	1				
7	1WD-E5451-00	GASKET, CRANKCASE COVER 1	1				
8	99530-08012	PIN, DOWEL	2				
9	95022-06025	BOLT, FLANGE	9				
10	1WD-E5461-00	GASKET, CRANKCASE COVER 2	1				
11	99530-08012	PIN, DOWEL	2				
12	95022-06025	BOLT, FLANGE	9				
13	95022-06050	BOLT, FLANGE	1				
14	1WD-E5441-10	HOLDER, CLUTCH CABLE	1				
15	90110-06178	BOLT, HEXAGON SOCKET HEAD	2				
16	1WD-E5413-10	COVER	1				
17	B1X-E5462-00	GASKET, CRANKCASE COVER 3	1				
18	95022-06025	BOLT, FLANGE	8				
19	90462-08819	CLAMP	1				
20	90462-08806	CLAMP	1				
21	BS7-E5377-00	GUIDE, INLET	1				
22	1WD-E5418-00	COVER, CHAIN CASE	1				
23	95022-06025	BOLT, FLANGE	2				

**FIG. 12 STARTER CLUTCH**



REF. NO.	PART NO.	DESCRIPTION	BFA1				REMARKS
1	1WD-E5514-00	GEAR 2	1				
2	44D-E5521-00	SHAFT 1	1				
3	1WD-E5515-10	GEAR 3	1				
4	1WD-E5580-00	STARTER CLUTCH OUTER ASSY	1				
5	90110-06161	BOLT, HEXAGON SOCKET HEAD	3				
-----							
-----							
-----							
-----							
-----							
-----							
-----							
-----							
-----							
-----							

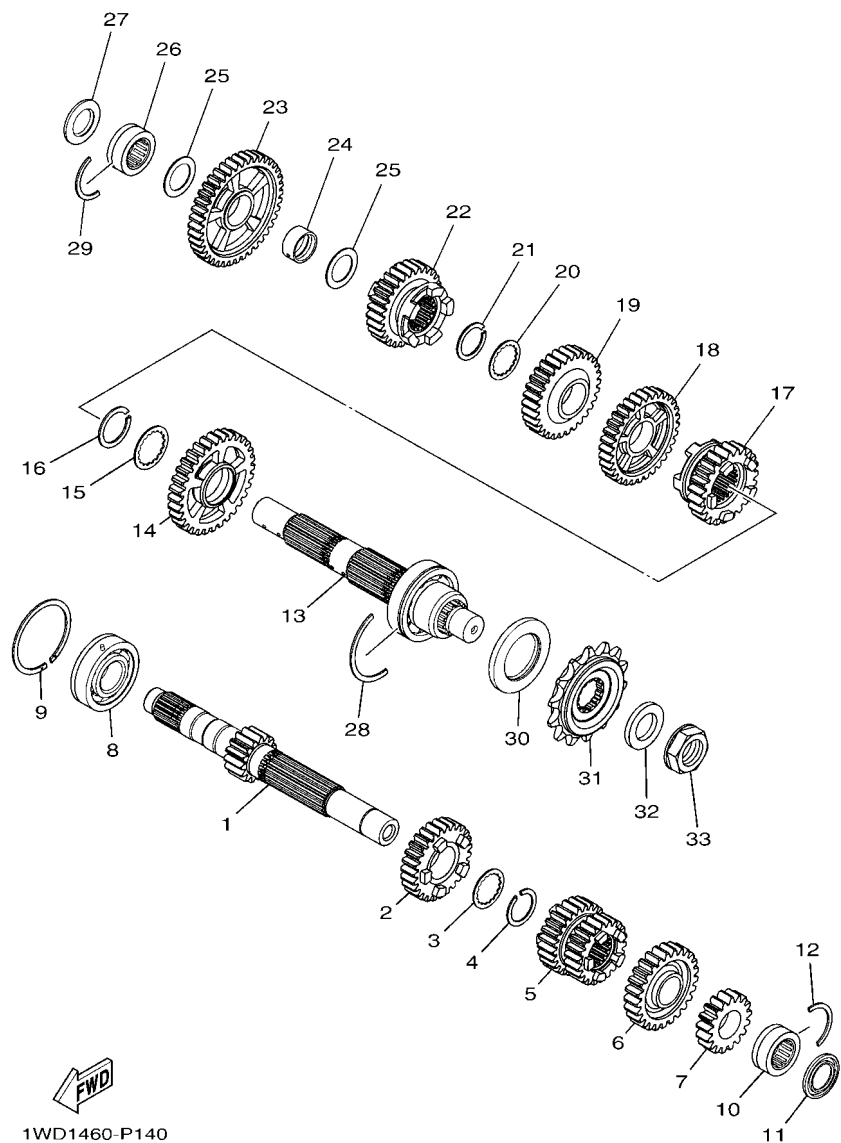
**FIG. 13 CLUTCH**



1WD1460-P130

REF. NO.	PART NO.	DESCRIPTION	BFA1				REMARKS
1	1WD-E6111-00	GEAR, PRIMARY DRIVE	1				
2	1WD-E6150-00	PRIMARY DRIVEN GEAR COMP.	1				
3	1WD-E6154-00	PLATE, THRUST 1	1				
4	1WD-E6371-00	BOSS, CLUTCH	1				
5	1WD-E6331-00	PLATE, FRICTION 2	6				
6	1WD-E6324-00	PLATE, CLUTCH 1	5				
7	1WD-E6350-01	PRESSURE PLATE ASSY	1				
8	1WD-E6333-10	SPRING, CLUTCH 1	4				
9	1WD-E6337-00	SCREW, SPRING	4				
10	90215-18800	WASHER, LOCK	1				
11	90170-18221	NUT	1				
12	90201-22013	WASHER, PLATE	1				
13	1WD-E6181-00	SPACER 1	1				
14	1WD-E6356-00	ROD, PUSH 1	1				
15	1WD-E6340-00	PUSH LEVER ASSY	1				
16	90201-10843	WASHER, PLATE	1				
17	99009-10400	CIRCLIP	1				
18	90508-18136	SPRING, TORSION	1				
19	1WD-16382-00	AXLE, PUSH LEVER	1				
20	92902-08600	WASHER, PLATE	1				
21	99002-07600	CIRCLIP(E)	1				

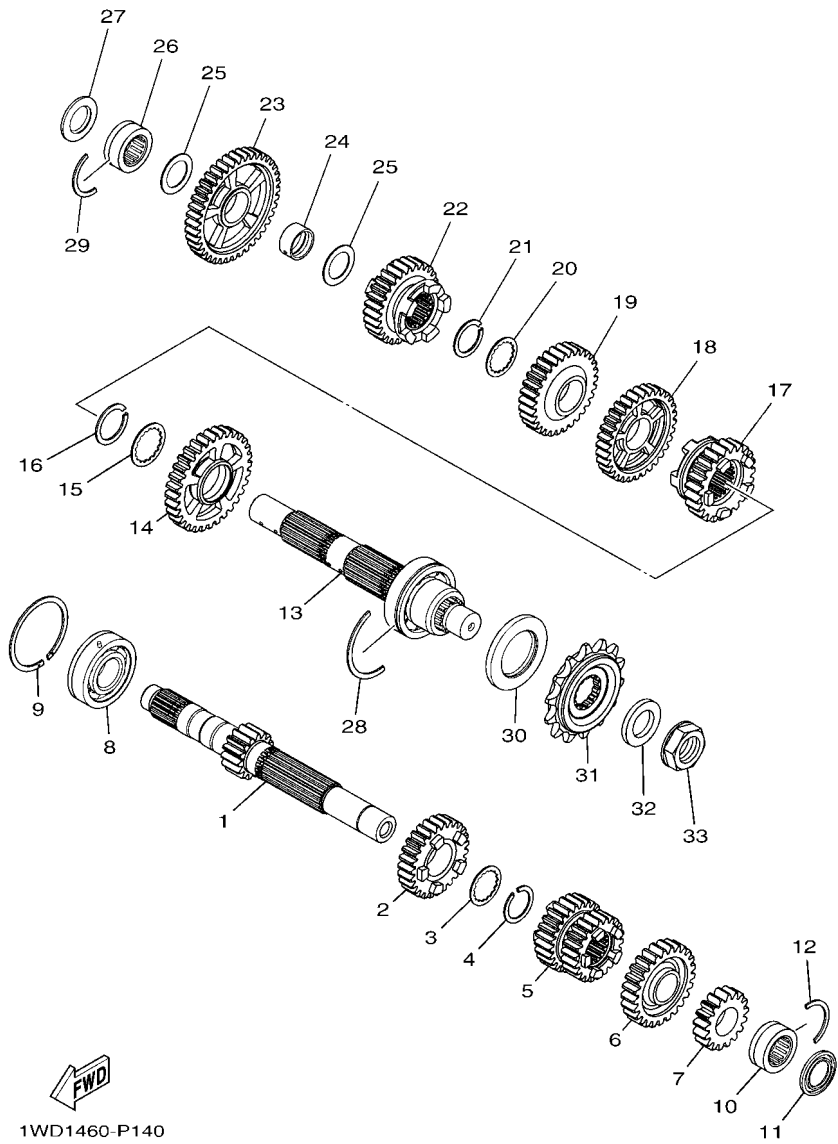
**FIG. 14 TRANSMISSION**



1WD1460-P140

REF. NO.	PART NO.	DESCRIPTION	BFA1				REMARKS
1	1WD-E7411-01	AXLE, MAIN (15T)	1				UR
	1WD-E7411-10	AXLE, MAIN (15T)	1				UR
2	1WD-E7151-01	GEAR, 5TH PINION (27T)	1				
3	90214-22008	WASHER, CLAW	1				
4	93440-24200	CIRCLIP	1				
5	1WD-E7131-00	GEAR, 3RD PINION (22T/25T)	1				
6	1WD-E7161-01	GEAR, 6TH PINION (25T)	1				
7	1WD-E7121-00	GEAR, 2ND PINION (17T)	1				
8	93306-255Y9	BEARING	1				
9	93440-52009	CIRCLIP	1				
10	93311-420Y3	BEARING	1				
11	93101-20802	OIL SEAL	1				
12	278-17425-00	CIRCLIP 2	1				
13	1WD-E7402-00	DRIVE AXLE ASSY	1				
14	1WD-E7221-00	GEAR, 2ND WHEEL (32T)	1				
15	90209-25011	WASHER	1				
16	93440-28184	CIRCLIP	1				
17	1WD-E7261-00	GEAR, 6TH WHEEL (23T)	1				
18	1WD-E7231-00	GEAR, 3RD WHEEL (32T)	1				
19	1WD-E7241-00	GEAR, 4TH WHEEL (30T)	1				
20	90214-22008	WASHER, CLAW	1				
21	93440-24200	CIRCLIP	1				
22	1WD-E7251-00	GEAR, 5TH WHEEL (28T)	1				
23	1WD-E7211-00	GEAR, 1ST WHEEL (40T)	1				
24	90387-20814	COLLAR	1				
25	90201-20276	WASHER, PLATE (T=1.0)	2				
26	93311-420Y3	BEARING	1				

**FIG. 14 TRANSMISSION**

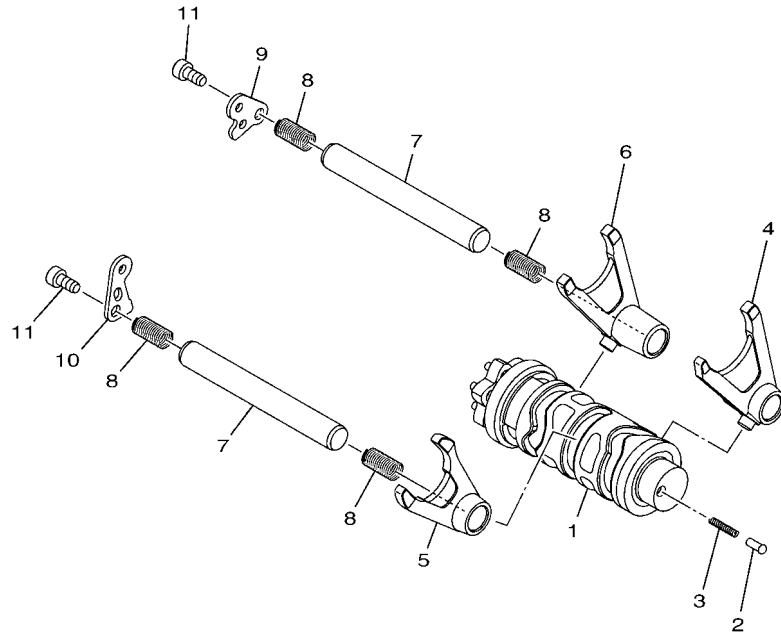


1WD1460-P140

REF. NO.	PART NO.	DESCRIPTION	BFA1				REMARKS
27	93101-20802	OIL SEAL	1				
28	1WD-17424-00	CIRCLIP 1	1				
29	278-17425-00	CIRCLIP 2	1				
30	93102-35808	OIL SEAL	1				
31	1WD-E7460-00	SPROCKET, DRIVE (14T)	1				
32	90201-20023	WASHER, PLATE	1				
33	90179-20013	NUT	1				

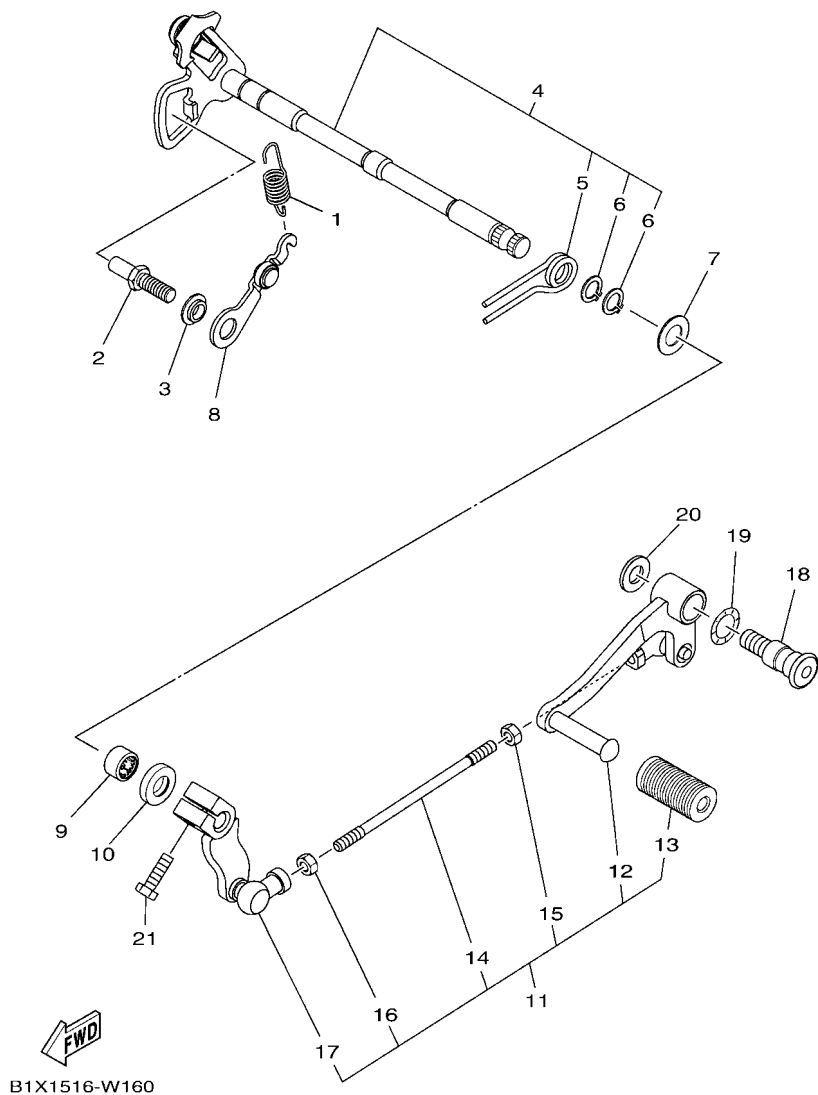


**FIG. 15 SHIFT CAM & FORK**

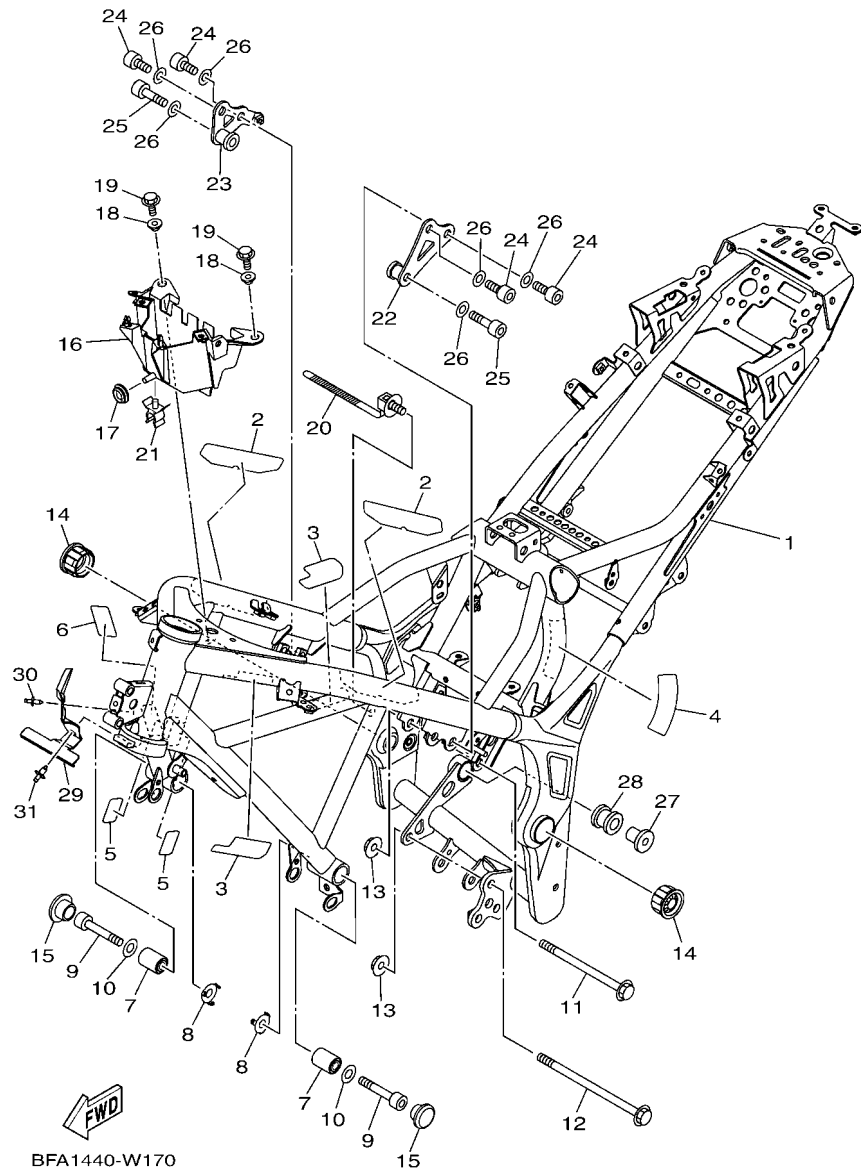


REF. NO.	PART NO.	DESCRIPTION	BFA1				REMARKS
1	1WD-E8540-10	SHIFT CAM ASSY	1				
2	5TP-E8542-00	POINT, NEUTRAL	1				
3	90501-06022	SPRING, COMPRESSION	1				
4	1WD-E8511-00	FORK, SHIFT 1	1				
5	1WD-E8512-00	FORK, SHIFT 2	1				
6	1WD-E8513-00	FORK, SHIFT 3	1				
7	1WD-E8531-00	BAR, SHIFT FORK GUIDE 1	2				
8	90501-080A2	SPRING, COMPRESSION	4				
9	1WD-E8536-00	STOPPER, SHIFT BAR	1				
10	1WD-E8562-00	PLATE, STOPPER 2	1				
11	90110-06182	BOLT, HEXAGON SOCKET HEAD	2				

**FIG. 16 SHIFT SHAFT**



REF. NO.	PART NO.	DESCRIPTION	BFA1				REMARKS
1	1WD-E8337-00	SPRING	1				
2	1WD-E8127-10	STOPPER, SCREW	1				
3	1WD-E8175-00	SPACER	1				
4	1WD-E8101-00	SHIFT SHAFT ASSY	1				
5	90508-29806	.SPRING, TORSION	1				
6	99009-12400	.CIRCLIP	2				
7	90201-127E1	WASHER, PLATE	1				
8	1WD-E8140-01	STOPPER LEVER ASSY	1				
9	93317-11295	BEARING	1				
10	93102-12891	OIL SEAL	1				
11	B1X-E8110-00	SHIFT PEDAL ASSY	1				
12	1WD-E8111-00	.PEDAL, SHIFT	1				
13	1EG-E8113-01	.COVER, SHIFT PEDAL	1				
14	1WD-E8115-00	.ROD, SHIFT	1				
15	90170-06023	.NUT	1				
16	95302-06600	.NUT, HEXAGON	1				
17	B1X-E8112-00	.ARM, SHIFT	1				
18	BS8-F7261-00	SHAFT	1				
19	90206-14001	WASHER, WAVE	1				
20	90201-10021	WASHER, PLATE	1				
21	97012-06020	BOLT	1				

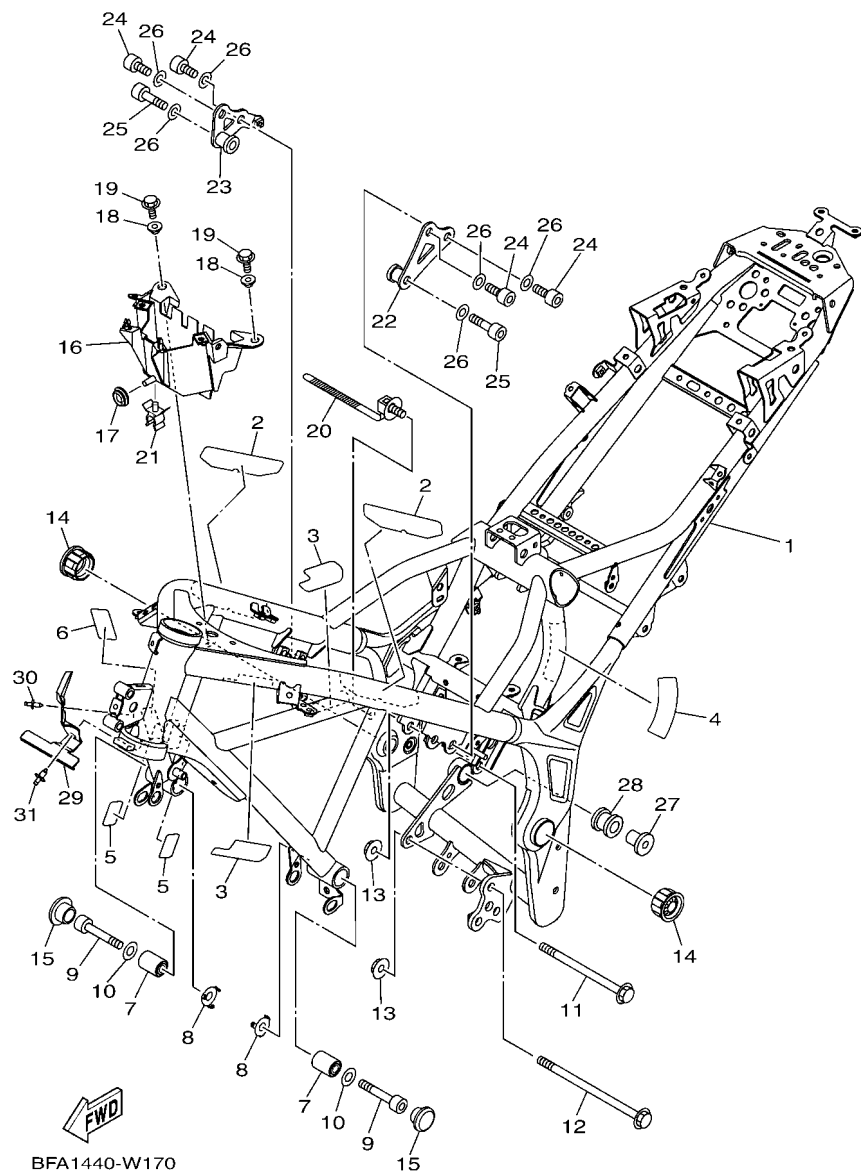


BFA1440-W170

FIG. 17 FRAME

REF. NO.	PART NO.	DESCRIPTION	BFA1				REMARKS
1	1WD-F1110-13	FRAME COMP.	1				MBL2
2	1WD-F112C-00	DAMPER 2	2				
3	1WD-F117G-00	PROTECTOR	2				
4	1WD-F1652-00	PROTECTOR	1				
5	1WD-F193A-00	PROTECTOR	2				
6	5D9-F414G-00	SEAL	1				
7	90388-10816	DAMPER	2				
8	1WD-F191B-00	PLATE 1	2				
9	91317-10060	BOLT, HEXAGON SOCKET HEAD	2				
10	90201-10854	WASHER, PLATE	2				
11	90105-10889	BOLT, FLANGE	1				
12	90105-10891	BOLT, FLANGE	1				
13	90179-10805	NUT	2				
14	1WD-F135F-00	COVER	2				
15	90338-23801	PLUG	2				
16	1WD-F1171-00	BOX	1				
17	90480-13398	GROMMET	1				
18	90387-07819	COLLAR	2				
19	95022-06014	BOLT, FLANGE	2				
20	90464-30009	CLAMP	1				
21	90464-12015	CLAMP	1				
22	B1X-F122A-00	STAY 1	1				
23	1WD-F122B-00	STAY 2	1				
24	91317-10020	BOLT, HEXAGON SOCKET HEAD	4				
25	91317-10045	BOLT, HEXAGON SOCKET HEAD	2				
26	92907-10600	WASHER, PLATE	6				
27	90387-08813	COLLAR	1				

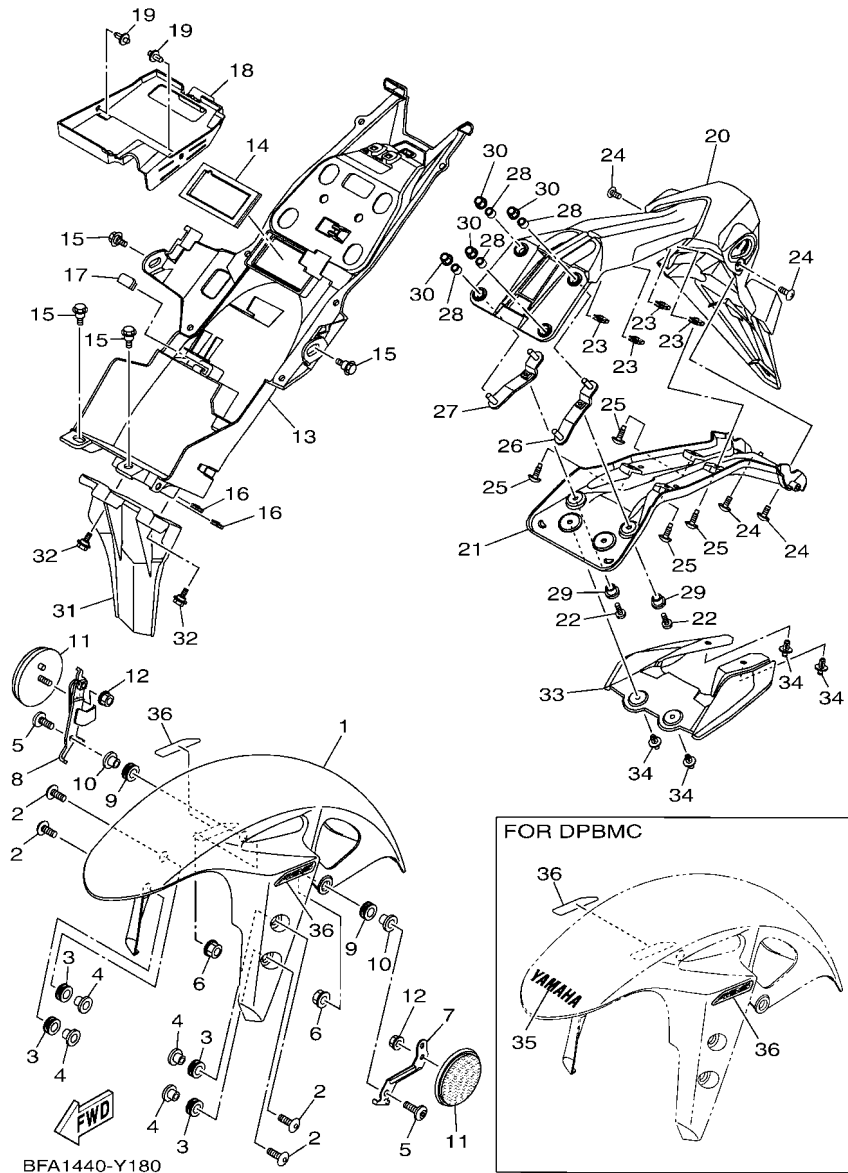
FIG. 17 FRAME



BFA1440-W170

REF. NO.	PART NO.	DESCRIPTION	BFA1				REMARKS
28	5TP-E4747-00	DAMPER, MUFFLER	1				
29	BS7-F612N-00	BRACKET 5	1				
30	90269-05008	RIVET	1				
31	90269-07007	RIVET	1				
-----							
-----							
-----							
-----							
-----							
-----							
-----							
-----							
-----							
-----							

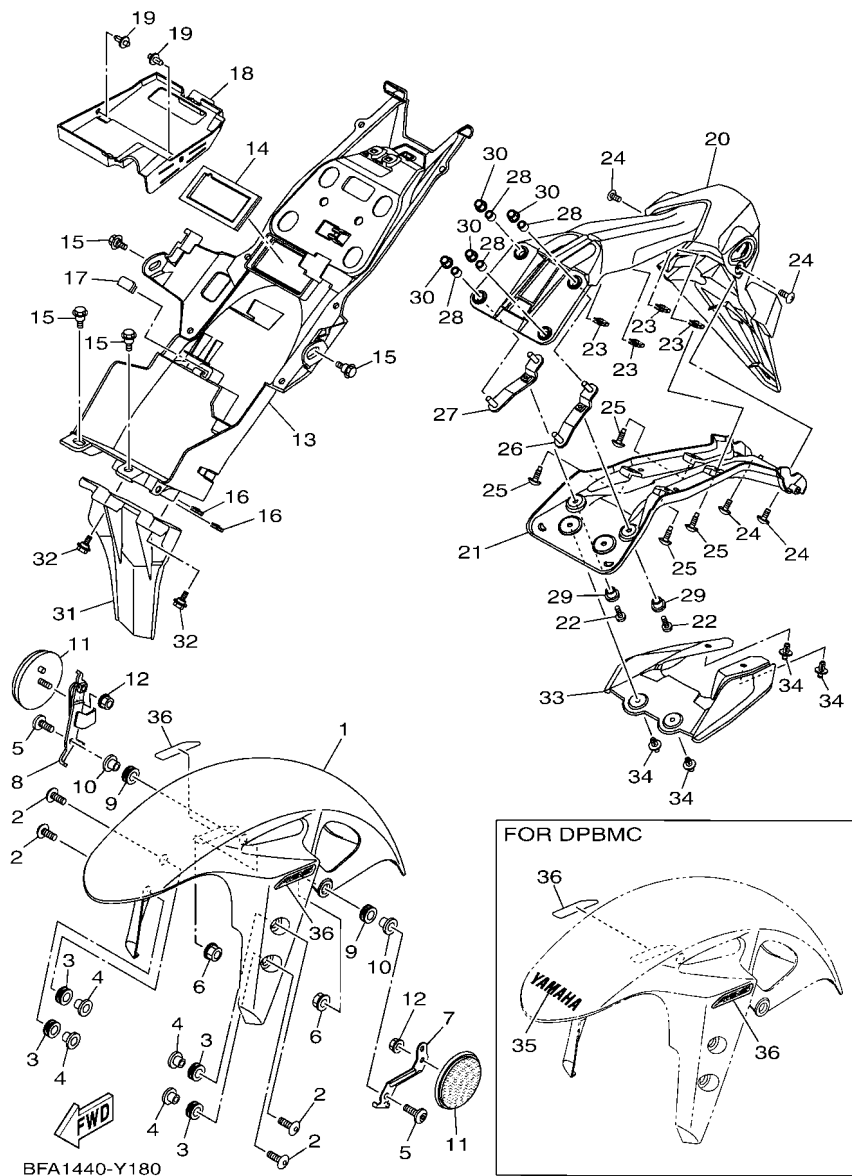
FIG. 18 FENDER



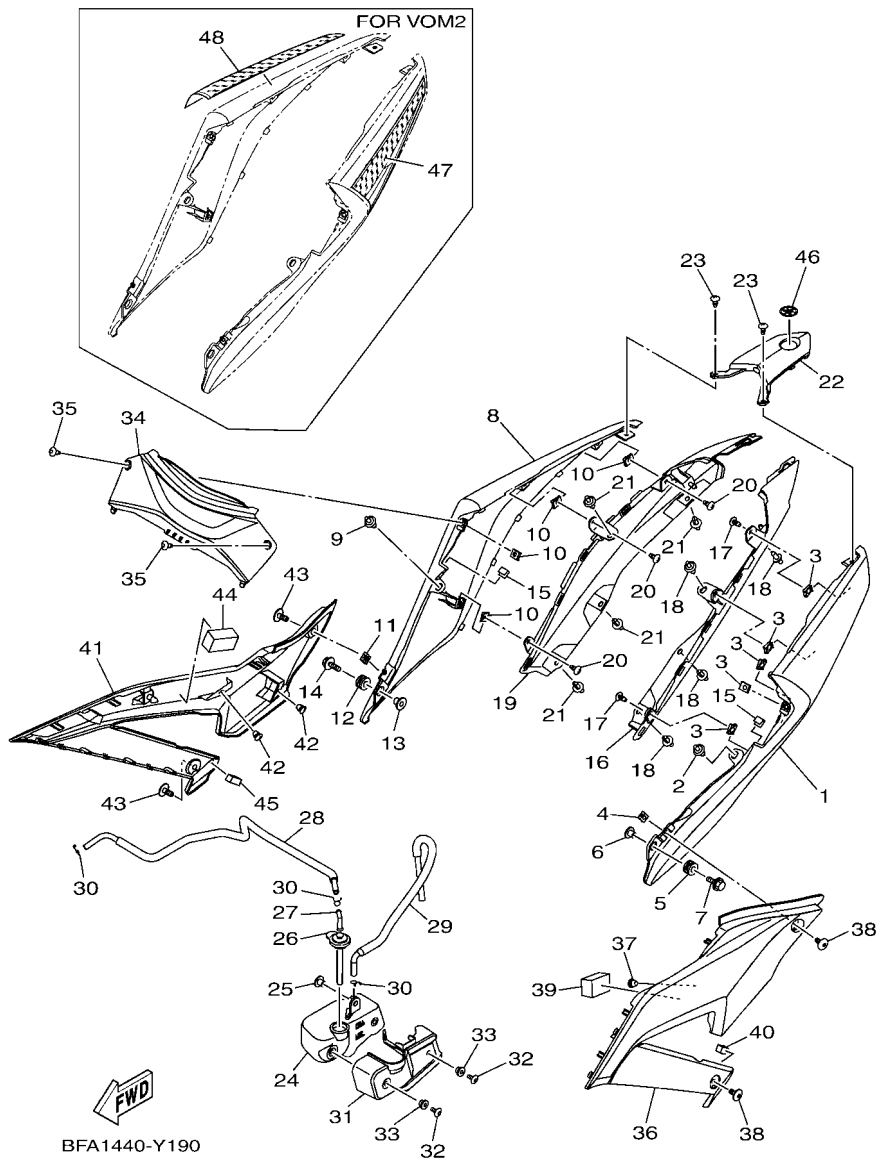
BFA1440-Y180

REF. NO.	PART NO.	DESCRIPTION	BFA1	REMARKS
1	BS7-F1511-00-PA	FENDER, FRONT	1	UR MBM3 FOR DPBMC
	BS7-F1511-00-PB	FENDER, FRONT	1	UR FOR VOM2
2	90111-06137	BOLT, HEXAGON SOCKET BUTTON	4	
3	90480-12808	GROMMET	4	
4	90387-06899	COLLAR	4	
5	90111-06847	BOLT, HEXAGON SOCKET BUTTON	2	
6	95702-06500	NUT, FLANGE	2	
7	B5L-F113J-00	BRACKET, REFLECTOR 1	1	
8	B5L-F113K-01	BRACKET, REFLECTOR 2	1	
9	90480-12808	GROMMET	2	
10	90387-06899	COLLAR	2	
11	2FC-H5111-00	REFLECTOR, 1	2	
12	95702-05500	NUT, FLANGE	2	
13	BR5-F1611-01	FENDER, REAR	1	
14	1WD-F1669-00	SEAL	1	
15	90109-063F1	BOLT	4	
16	90183-05076	NUT, SPRING	2	
17	1WD-F16A2-00	SEAL, 2	1	
18	BR5-F163E-01	COVER, REAR FENDER 2	1	
19	90269-06816	RIVET	2	
20	B1X-F1629-00	GUARD, MUD	1	
21	1WD-F1617-01	BRACKET, FENDER	1	
22	90111-05021	BOLT, HEXAGON SOCKET BUTTON	2	
23	90183-050A7	NUT, SPRING	4	
24	97707-50016	SCREW, TRUSS HEAD TAPPING	4	
25	90111-05018	BOLT, HEXAGON SOCKET BUTTON	4	
26	1WD-F1688-00	BRACKET, REAR STAY	1	

FIG. 18 FENDER



REF. NO.	PART NO.	DESCRIPTION	BFA1				REMARKS
27	1WD-F1689-00	BRACKET, REAR STAY 2	1				
28	90387-066J9	COLLAR	4				
29	90387-068L9	COLLAR	2				
30	95602-06200	NUT, SELF-LOCKING	4				
31	1WD-F1621-01	FLAP	1				
32	90109-05003	BOLT	2				
33	1WD-F163A-00	COVER, REAR FENDER 1	1				
34	90269-06816	RIVET	4				
35	1WD-F153E-50	EMBLEM, YAMAHA	1				FOR DPBMC
36	B5P-F1569-A0	GRAPHIC 1	2				UR FOR DPBMC
	B5P-F1569-C0	GRAPHIC 1	2				UR FOR VOM2



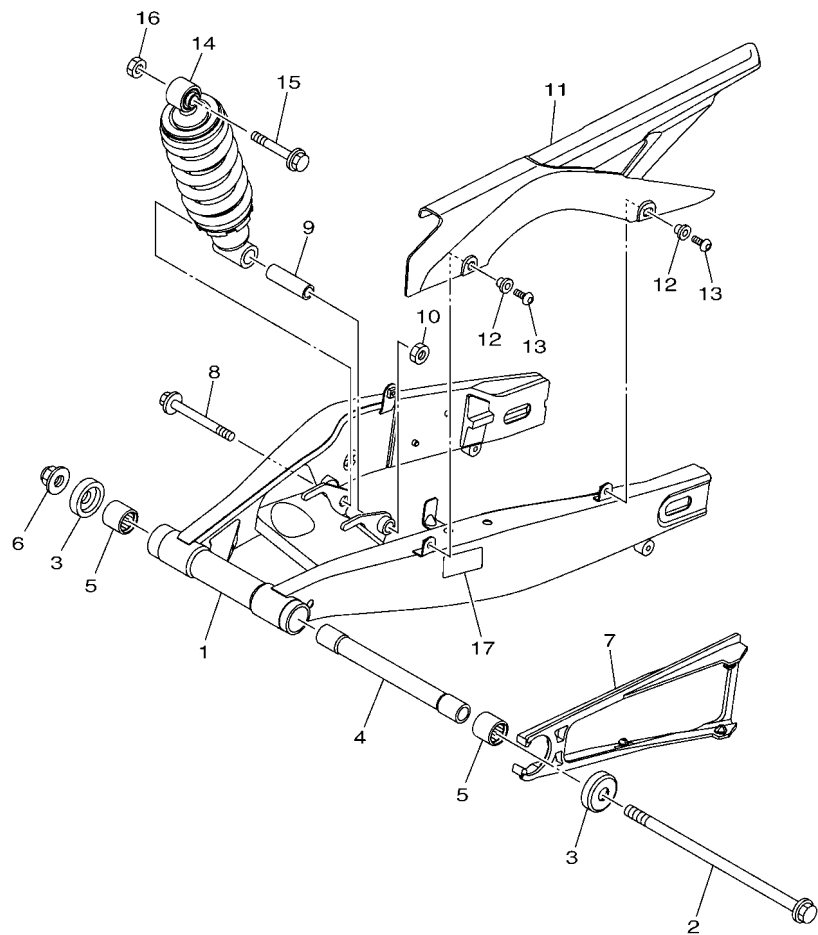
**FIG. 19 SIDE COVER**

REF. NO.	PART NO.	DESCRIPTION	BFA1				REMARKS
1	1WD-F1711-00-P1	COVER, SIDE 1	1				UR FOR DPBMC
	1WD-F1711-00-P4	COVER, SIDE 1	1				UR MNM3 FOR VOM2
2	90269-06816	RIVET	1				
3	90183-05807	NUT, SPRING	5				
4	90183-050A7	NUT, SPRING	1				
5	90480-12808	GROMMET	1				
6	90387-06899	COLLAR	1				
7	90119-06810	BOLT, WITH WASHER	1				
8	1WD-F1721-00-P1	COVER, SIDE 2	1				UR FOR DPBMC
	1WD-F1721-00-P4	COVER, SIDE 2	1				UR MNM3 FOR VOM2
9	90269-06816	RIVET	1				
10	90183-05807	NUT, SPRING	4				
11	90183-050A7	NUT, SPRING	1				
12	90480-12808	GROMMET	1				
13	90387-06899	COLLAR	1				
14	90119-06810	BOLT, WITH WASHER	1				
15	31B-F8307-00	SEAL	2				
16	1WD-F171L-00	MOLE, SIDE COVER 1	1				
17	97707-50016	SCREW, TRUSS HEAD TAPPING	2				
18	90269-06816	RIVET	4				
19	1WD-F171M-00	MOLE, SIDE COVER 2	1				
20	97707-50016	SCREW, TRUSS HEAD TAPPING	3				
21	90269-06816	RIVET	4				
22	1WD-F171N-00	MOLE, SIDE COVER 3	1				
23	97707-50016	SCREW, TRUSS HEAD TAPPING	2				
24	1WD-F1871-01	TANK, RECOVERY	1				
25	90387-06857	COLLAR	1				





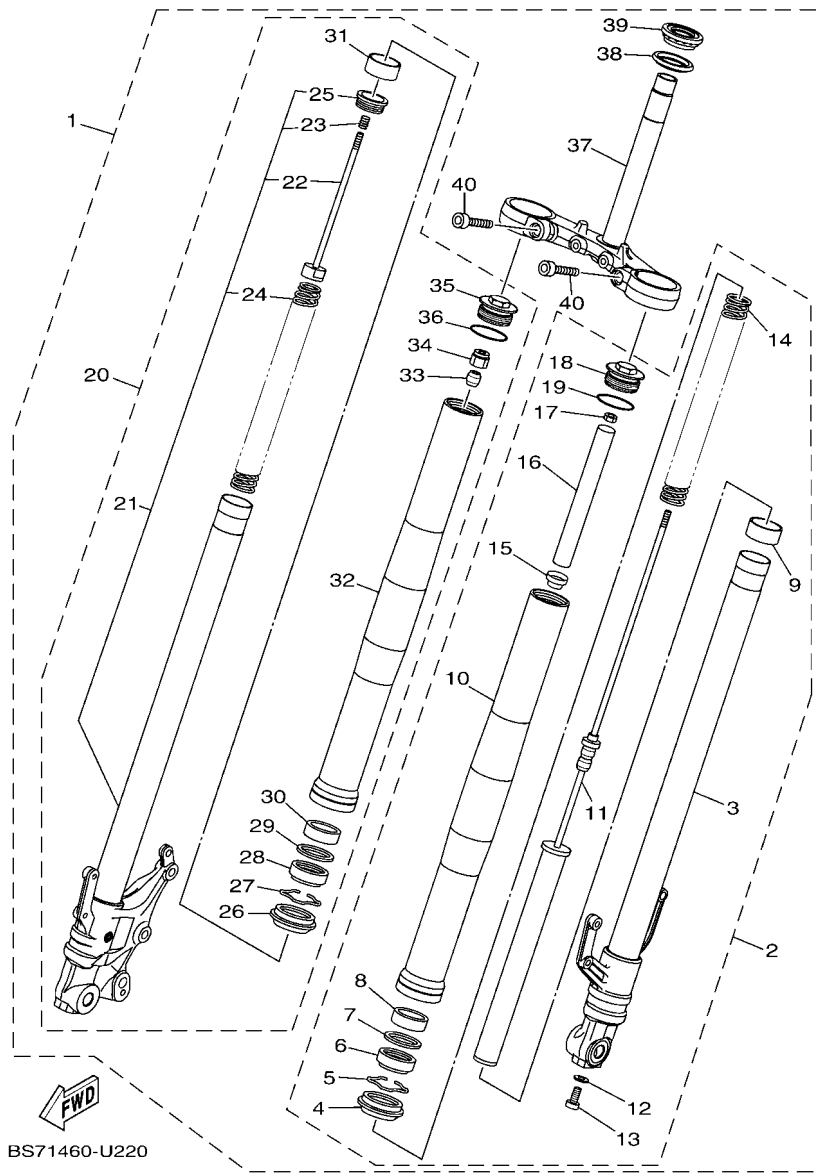
**FIG. 20 REAR ARM & SUSPENSION**



  
B5L1422-U200

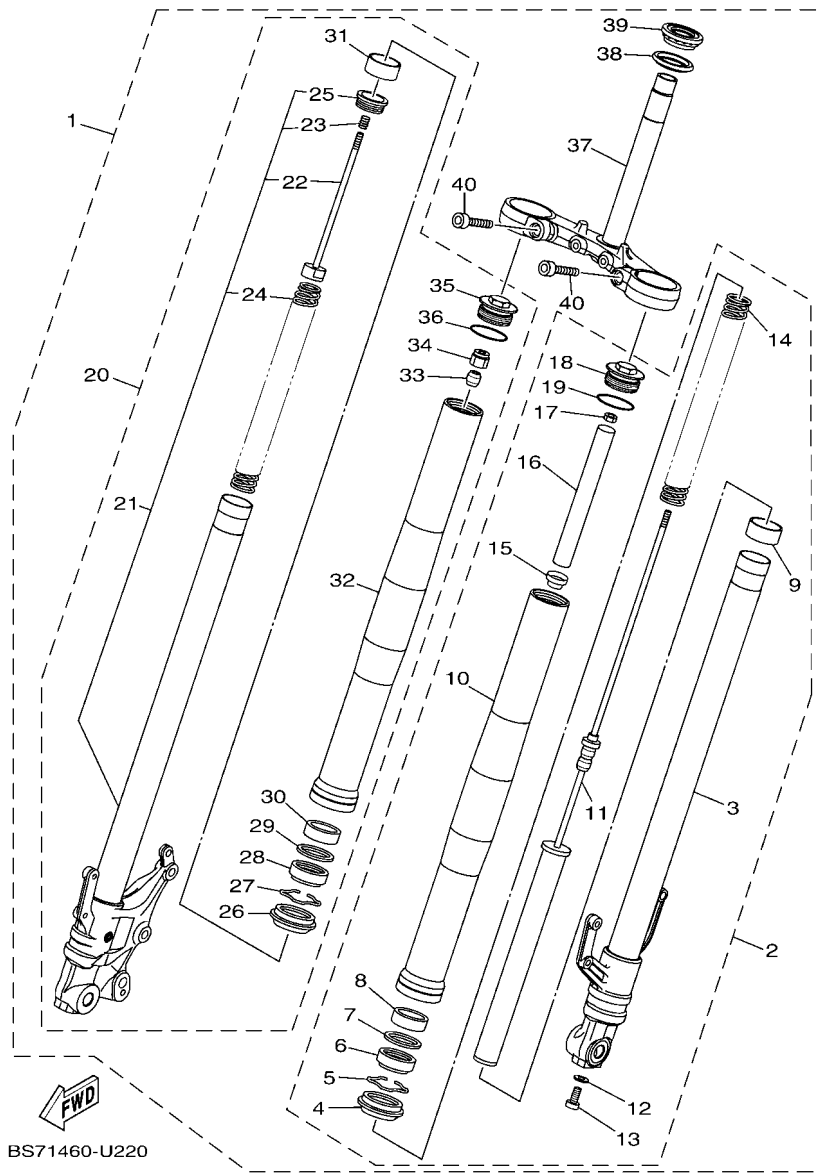
REF. NO.	PART NO.	DESCRIPTION	BFA1				REMARKS
1	1WD-F2110-00	REAR ARM COMP.	1				MBL2
2	1WD-22141-00	SHAFT, PIVOT	1				
3	1WD-F2129-01	COVER, THRUST 2	2				
4	1WD-F2184-00	BUSH	1				
5	93320-32403	BEARING	2				
6	95602-14200	NUT, SELF-LOCKING	1				
7	1WD-F2151-00	SEAL, GUARD	1				
8	90105-12309	BOLT, FLANGE	1				
9	1WD-F248B-00	COLLAR, ROD 1	1				
10	95602-12100	NUT, U	1				
11	1WD-F2311-01	CASE, CHAIN	1				
12	90387-06242	COLLAR	2				
13	90111-06119	BOLT, HEXAGON SOCKET BUTTON	2				
14	BS7-F2210-00	SHOCK ABSORBER ASSY, REAR	1				
15	90105-12093	BOLT, FLANGE	1				
16	95602-12100	NUT, U	1				
17	B17-F1668-00	LABEL, TIRE	1				





**FIG. 22 FRONT FORK**

REF. NO.	PART NO.	DESCRIPTION	BFA1				REMARKS
1	B5L-F3100-00	FRONT FORK ASSY	1				
2	BS7-F3102-00	.FRONT FORK ASSY (L.H)	1				
3	BS7-F3110-00	..INNER TUBE COMP.1	1				
4	B48-F3144-00	..SEAL, DUST	1				
5	3R4-23153-00	..RING, SNAP	1				
6	BK6-F3145-00	..OIL SEAL	1				
7	31A-23149-31	..WASHER, SPRING UPPER	1				
8	31A-23125-31	..METAL, SLIDE 1	1				
9	BK6-F3171-00	..PISTON, FRONT FORK	1				
10	BS7-F3126-10	..TUBE, OUTER	1				
11	BS7-F3170-00	..CYLINDER COMP., FRONT FORK	1				
12	2BU-F3158-00	..GASKET	1				
13	31B-F3181-00	..BOLT, HEXAGON SOCKET HEAD	1				
14	BS7-F3141-00	..SPRING, FRONT FORK	1				
15	BK6-F3117-00	..GUIDE, SPRING	1				
16	BS7-F3118-00	..SPACER	1				
17	BK6-F3357-00	..NUT	1				
18	BS7-F3111-00	..BOLT, CAP	1				
19	4V4-23188-L0	..O-RING	1				
20	B5L-F3103-00	..FRONT FORK ASSY (R.H)	1				
21	B5L-F3120-00	..INNER TUBE COMP.2	1				
22	BK6-F330G-00	...ROD COMP.	1				
23	3AH-22222-00	...SPRING 2	1				
24	BS7-F3141-00	...SPRING, FRONT FORK	1				
25	BK6-F319U-00	...CAP	1				
26	B48-F3144-00	..SEAL, DUST	1				
27	3R4-23153-00	..RING, SNAP	1				



**FIG. 22 FRONT FORK**

REF. NO.	PART NO.	DESCRIPTION	BFA1				REMARKS
28	BK6-F3145-00	..OIL SEAL	1				
29	31A-23149-31	..WASHER, SPRING UPPER	1				
30	31A-23125-31	..METAL, SLIDE 1	1				
31	BK6-F3171-00	..PISTON, FRONT FORK	1				
32	BS7-F3126-10	..TUBE, OUTER	1				
33	BK6-F332K-00	..BUMP, STOP	1				
34	BK6-F3393-00	..NUT, SPECIAL	1				
35	BS7-F3111-00	..BOLT, CAP	1				
36	4V4-23188-L0	..O-RING	1				
37	BS7-F3340-00	..UNDER BRACKET COMP.	1				
38	3FV-23462-00	..SEAL, STEERING	1				
39	93399-99932	..BEARING	1				
40	91312-10040	..BOLT, HEXAGON SOCKET HEAD	2				

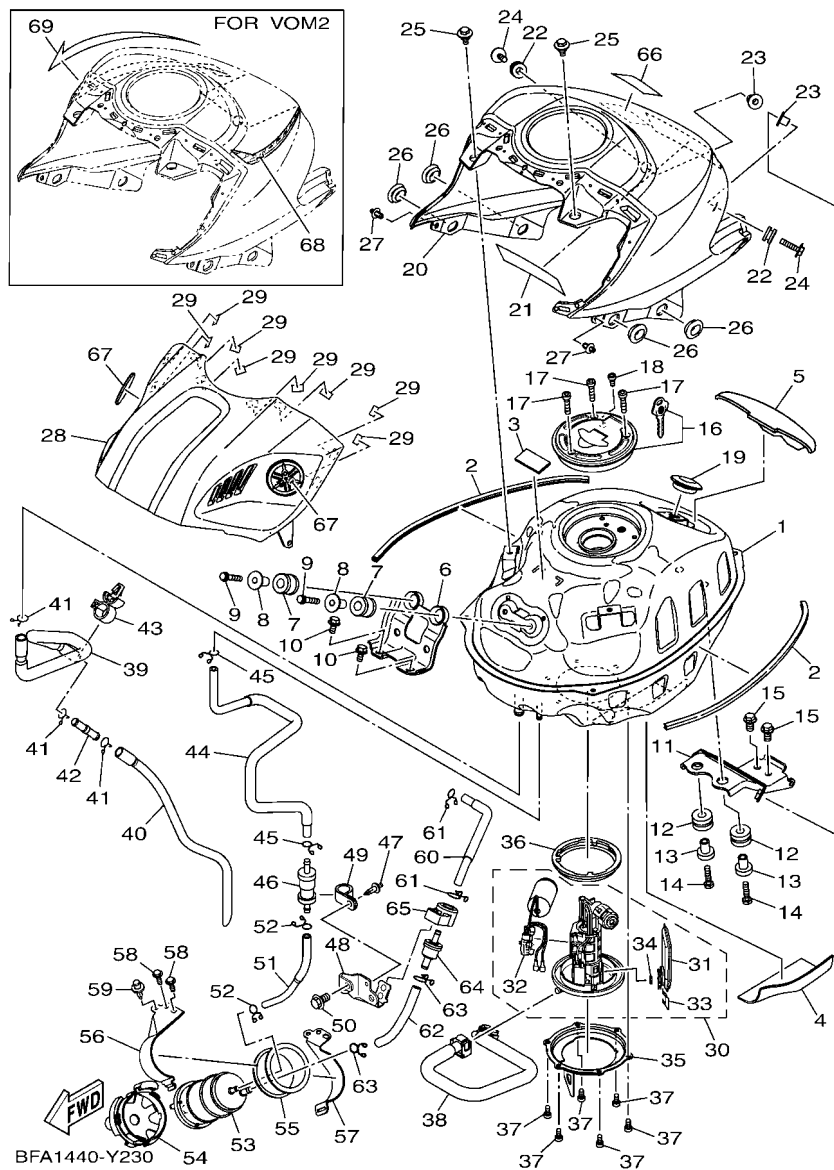
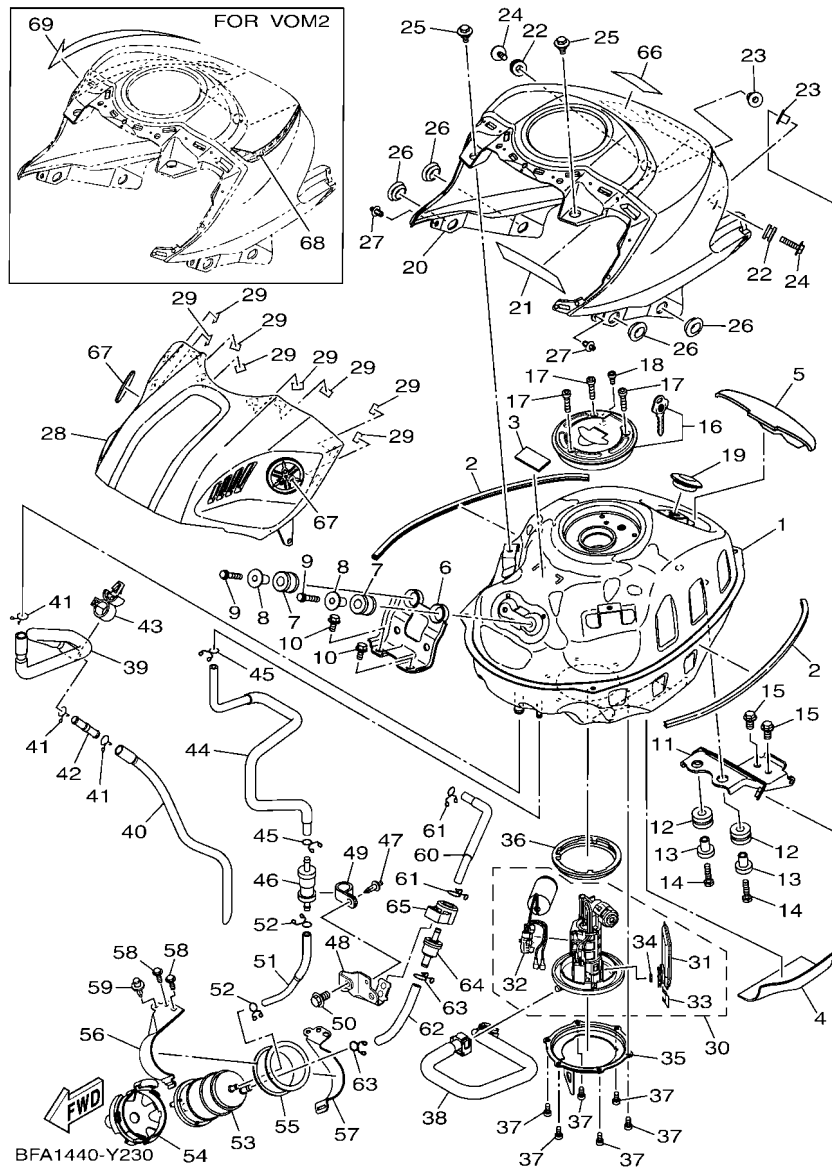


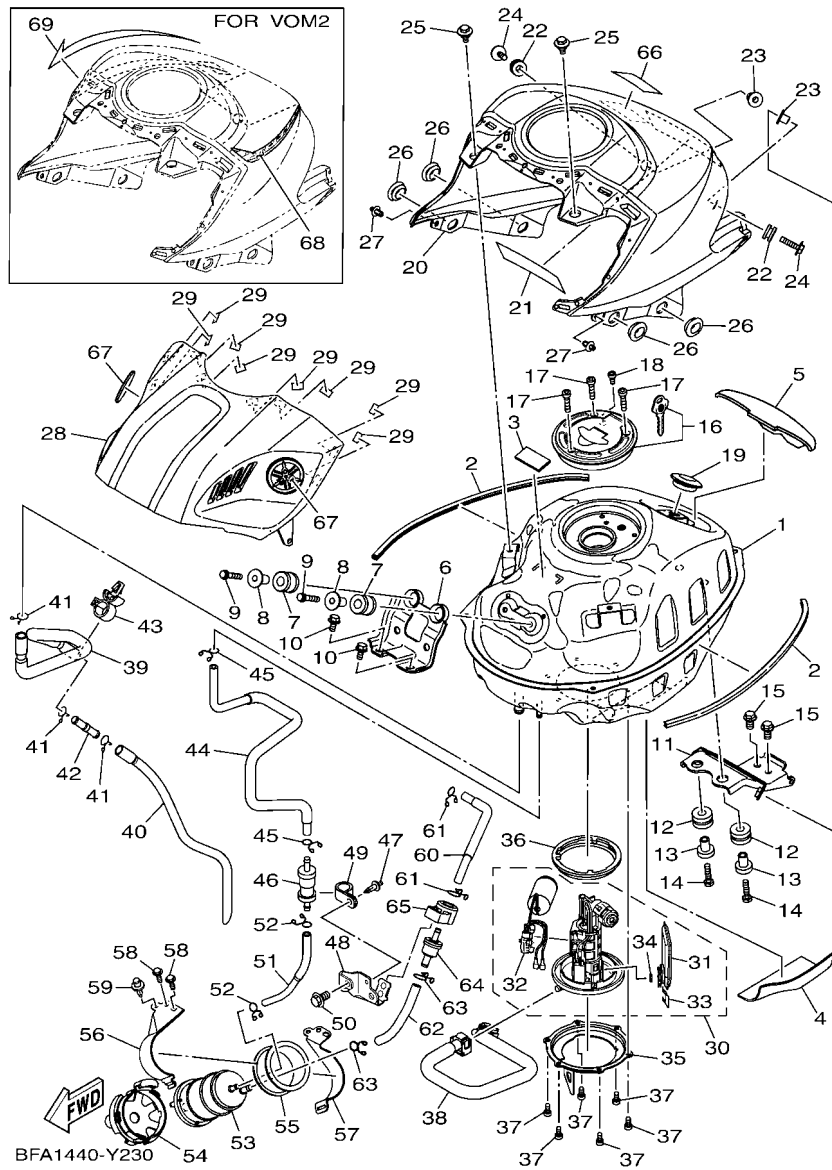
FIG. 23 FUEL TANK

REF. NO.	PART NO.	DESCRIPTION	BFA1	REMARKS
1	BS7-F4110-00	FUEL TANK COMP.	1	
2	BS7-F4188-00	MOLD, FUEL TANK	2	
3	5D9-H2126-00	PAD, BATTERY	1	
4	90520-02843	DAMPER, PLATE	1	
5	BS7-F414E-00	SEAL 2	1	
6	BS7-F412Y-00	BRACKET, TANK FITTING	1	
7	90480-18813	GROMMET	2	
8	90387-068M3	COLLAR	2	
9	97022-06030	BOLT, HEXAGON	2	
10	95817-06012	BOLT, FLANGE	2	
11	BS7-F4191-10	BRACKET, FUEL TANK 1	1	
12	90480-15807	GROMMET	2	
13	90387-068S8	COLLAR	2	
14	97022-06030	BOLT, HEXAGON	2	
15	95022-08014	BOLT, FLANGE	2	
16	BS7-WF461-00	CAP ASSY WITH LOCK	1	
17	90110-05806	BOLT, HEXAGON SOCKET HEAD	3	
18	91312-05010	BOLT, HEXAGON SOCKET HEAD	1	
19	90480-01806	GROMMET	1	
20	BS7-F41B1-00-P0	COVER, TANK	1	UR FOR DPBMC
	BS7-F41B1-00-P7	COVER, TANK	1	UR FOR VOM2
21	90520-03841	DAMPER, PLATE	1	
22	90480-12808	GROMMET	2	
23	90387-06899	COLLAR	2	
24	90119-06309	BOLT, WITH WASHER	2	
25	90109-068B2	BOLT	2	
26	90480-01559	GROMMET	4	



**FIG. 23 FUEL TANK**

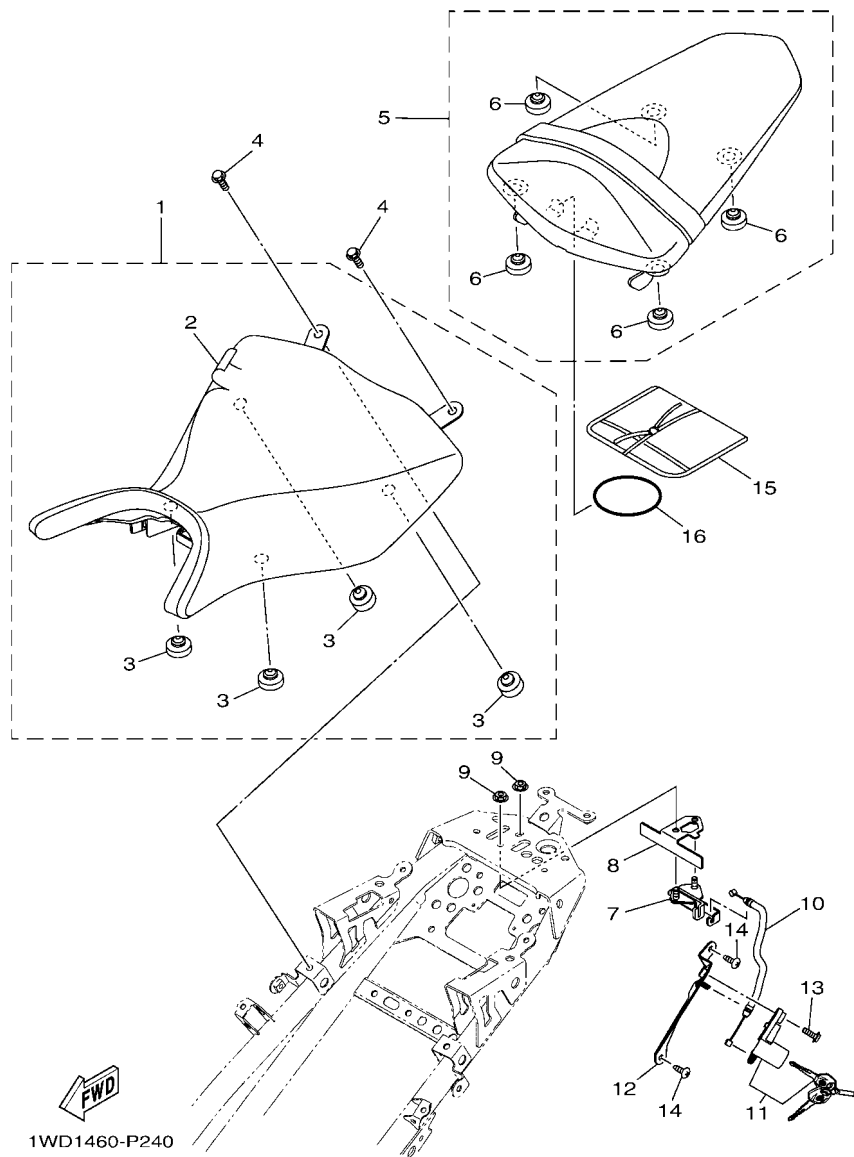
REF. NO.	PART NO.	DESCRIPTION	BFA1				REMARKS
27	90269-06816	RIVET	2				
28	BS7-F171A-01-P0	COVER, TOP	1				UR FOR DPBMC
	BS7-F171A-01-P7	COVER, TOP	1				UR FOR VOM2
29	31B-F8307-00	SEAL	8				
30	BS7-E3907-01	FUEL PUMP COMP.	1				
31	3C1-E3915-00	.FILTER	1				
32	BS7-H5752-00	.SENDER	1				
33	3C1-F4519-00	.CLIP	1				
34	3C1-24512-00	.GASKET	1				
35	BS7-F4491-00	BRACKET, FUEL PUMP	1				
36	3C1-F4486-00	O-RING	1				
37	91312-05010	BOLT, HEXAGON SOCKET HEAD	6				
38	1WD-E3971-02	PIPE, FUEL 1	1				
39	1WD-F4312-01	PIPE 2	1				
40	B9T-F4314-00	PIPE 4	1				
41	90467-15012	CLIP	3				
42	1WD-F4376-00	PIPE, JOINT 1	1				
43	90464-16012	CLAMP	1				
44	2MS-F4314-01	PIPE 4	1				
45	90467-09006	CLIP	2				
46	1DW-F4180-02	ROLL OVER VALVE ASSY	1				
47	90269-05008	RIVET	1				
48	B1X-F419F-00	BRACKET, CANISTOR	1				
49	90464-15014	CLAMP	1				
50	95027-08012	BOLT, FLANGE	1				
51	2MS-F4315-00	PIPE 5	1				
52	90467-09006	CLIP	2				



**FIG. 23 FUEL TANK**

REF. NO.	PART NO.	DESCRIPTION	BFA1				REMARKS
53	2MS-F4170-00	CANISTER ASSY	1				
54	B1X-F419E-00	COVER, CANISTER	1				
55	2MS-F483H-00	BAND	1				
56	2MS-F115R-00	BRACKET, CANISTER	1				
57	2MS-F134X-00	BRACKET, CANISTER	1				
58	95027-06016	BOLT, FLANGE	2				
59	90269-06816	RIVET	1				
60	B1X-F4316-00	PIPE 6	1				
61	90467-09006	CLIP	2				
62	B1X-F4317-00	PIPE 7	1				
63	90467-11009	CLIP	2				
64	B1X-F4421-00	VALVE, CHECK	1				
65	B1X-F419A-00	HOLDER	1				
66	26P-21568-11	LABEL, WARNING	1				
67	1WD-F413B-01	TUNING FORK MARK, 3D	2				
68	B5L-F4244-00	GRAPHIC, FUEL TANK 1	1				FOR VOM2
69	B5L-F4245-00	GRAPHIC, FUEL TANK 2	1				FOR VOM2

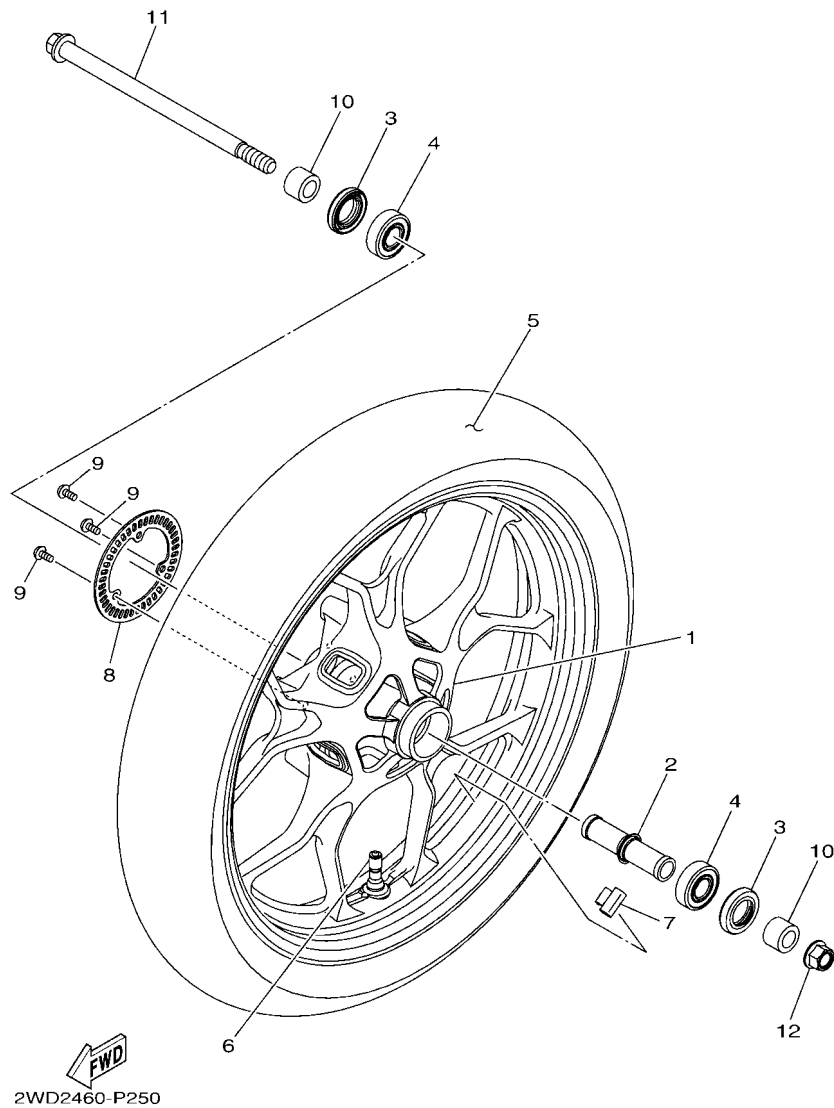
**FIG. 24 SEAT**



1WD1460-P240

REF. NO.	PART NO.	DESCRIPTION	BFA1				REMARKS
1	1WD-F4710-02	SINGLE SEAT ASSY	1				
2	1WD-F4711-01	.COVER, SINGLE SEAT	1				
3	5BP-F4741-00	.PAD, SEAT	4				
4	95022-06012	BOLT, FLANGE	2				
5	1WD-F4750-01	TANDEM SEAT ASSY	1				
6	3C1-F4741-00	.PAD, SEAT	4				
7	1WD-F4780-00	SEAT LOCK ASSY	1				
8	1WD-F4792-00	PLATE	1				
9	95707-06500	NUT, FLANGE	2				
10	1WD-F478E-00	CABLE, SEAT LOCK	1				
11	1WD-WF479-00	ROTOR SUB ASSY WITH KEY	1				
12	1WD-F117K-00	STAY, LOCK	1				
13	90159-06054	SCREW, WITH WASHER	1				
14	97702-50016	SCREW, TAPPING	2				
15	B9T-F8100-00	TOOL KIT	1				
16	5TL-H2131-00	BAND, BATTERY	1				

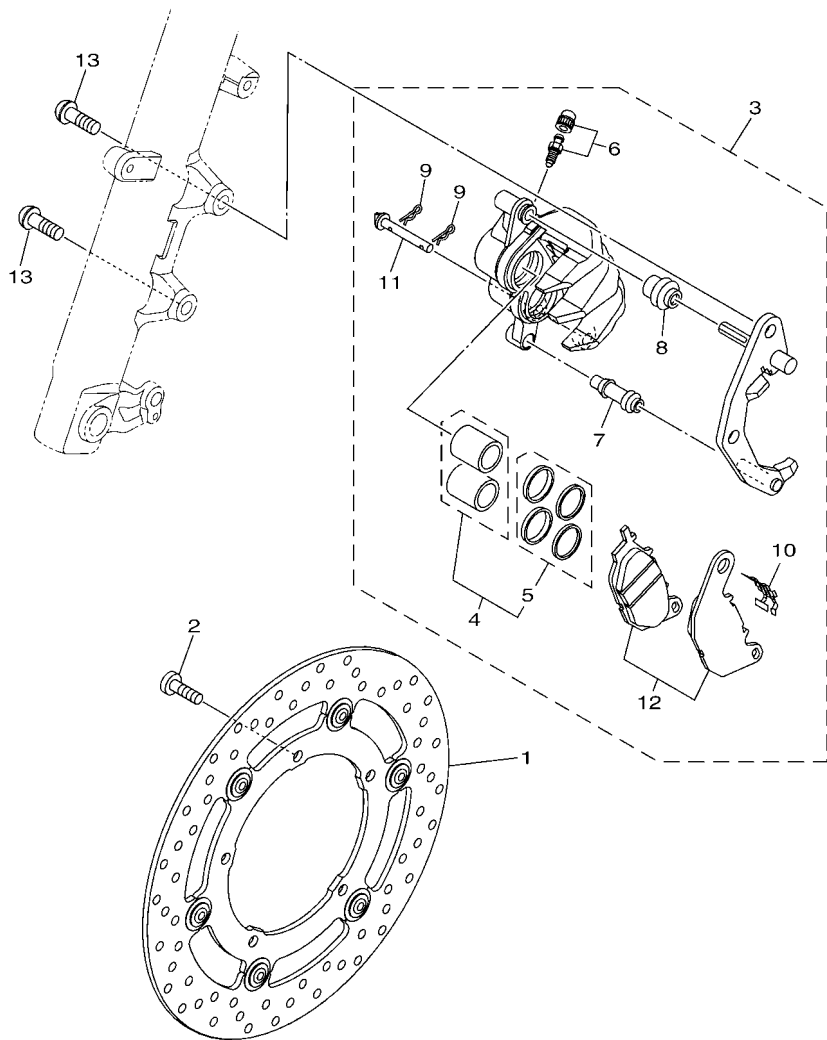




**FIG. 25 FRONT WHEEL**

REF. NO.	PART NO.	DESCRIPTION	BFA1				REMARKS
1	BS7-F5168-10-P0	CAST WHEEL, FRONT	1				DPBM15 FOR DPBMC
	BS7-F5168-10-98	CAST WHEEL, FRONT	1				LGB FOR VOM2
2	1WD-F510C-01	COLLAR ASSY.	1				
3	93106-26815	OIL SEAL	2				
4	93306-302X4	BEARING	2				
5	94111-17801	TIRE (110/70-17M/C 54S RX-01F)	1				INOUE
6	93900-00828	VALVE, RIM	1				
7	5MT-25398-00	BALANCER, WHEEL (10G)	1				UN
	5MT-25398-10	BALANCER, WHEEL (20G)	1				UN
	5MT-25398-20	BALANCER, WHEEL (30G)	1				UN
8	2DP-F517G-00	ROTOR, SENSOR	1				
9	90149-05029	SCREW	3				
10	1PA-F5386-00	COLLAR, SPROCKET AXLE	2				
11	1WD-25181-00	AXLE, WHEEL	1				
12	95602-14200	NUT, SELF-LOCKING	1				

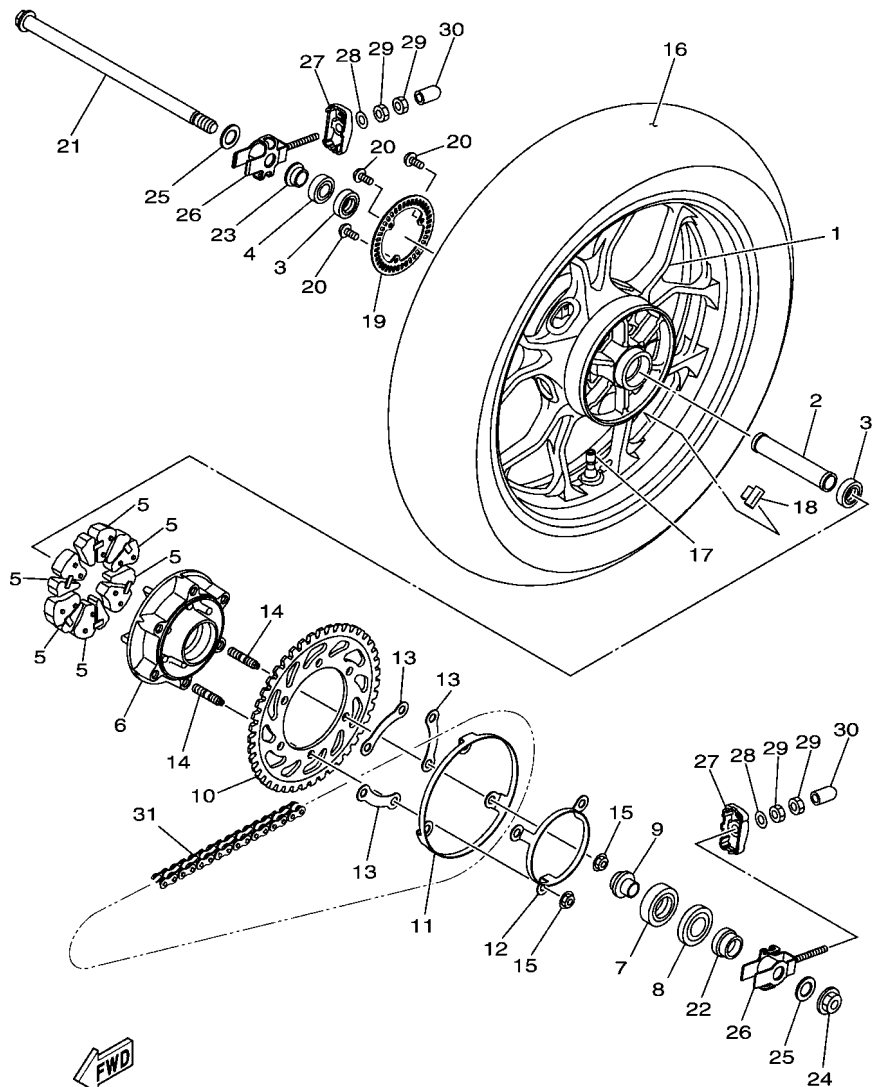
**FIG. 26 FRONT BRAKE CALIPER**



**FWD**  
1WD1460-P260

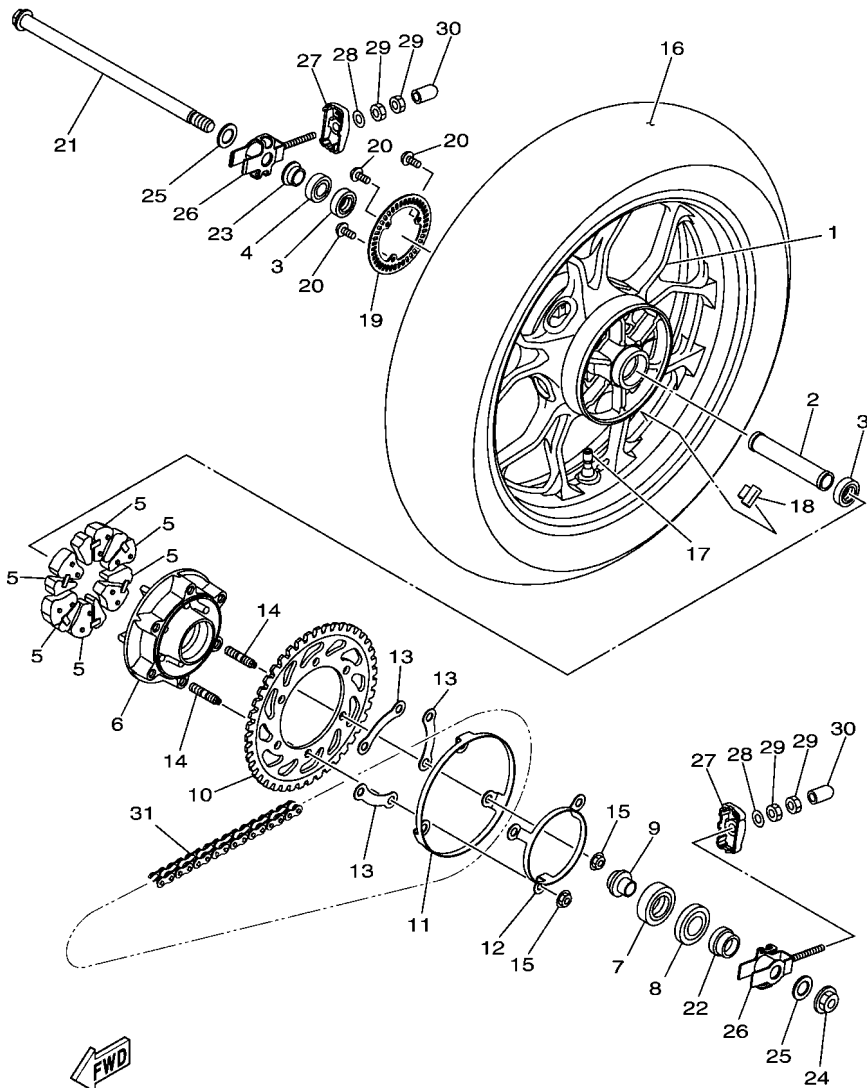
REF. NO.	PART NO.	DESCRIPTION	BFA1				REMARKS
1	1WD-F581U-01	DISK BRAKE ASSY (RIGHT)	1				
2	90111-08087	BOLT, HEXAGON SOCKET BUTTON	5				
3	1WD-F580U-01	CALIPER ASSY (RIGHT)	1				
4	1WD-25802-00	.PISTON ASSY, CALIPER	1				
5	1WD-25803-00	..CALIPER SEAL KIT	1				
6	4C9-W0048-00	..BLEED SCREW KIT	1				
7	5YP-F5937-00	..BOOT 2	1				
8	5YP-F5917-00	..BOOT, CALIPER	1				
9	5YP-F5925-01	..CLIP	2				
10	1WD-F5919-00	..SUPPORT, PAD	1				
11	5YP-F5924-00	..PIN, PAD	1				
12	1WD-25805-00	..BRAKE PAD KIT	1				
13	90149-10044	SCREW	2				

FIG. 27 REAR WHEEL



2WD2460-P271

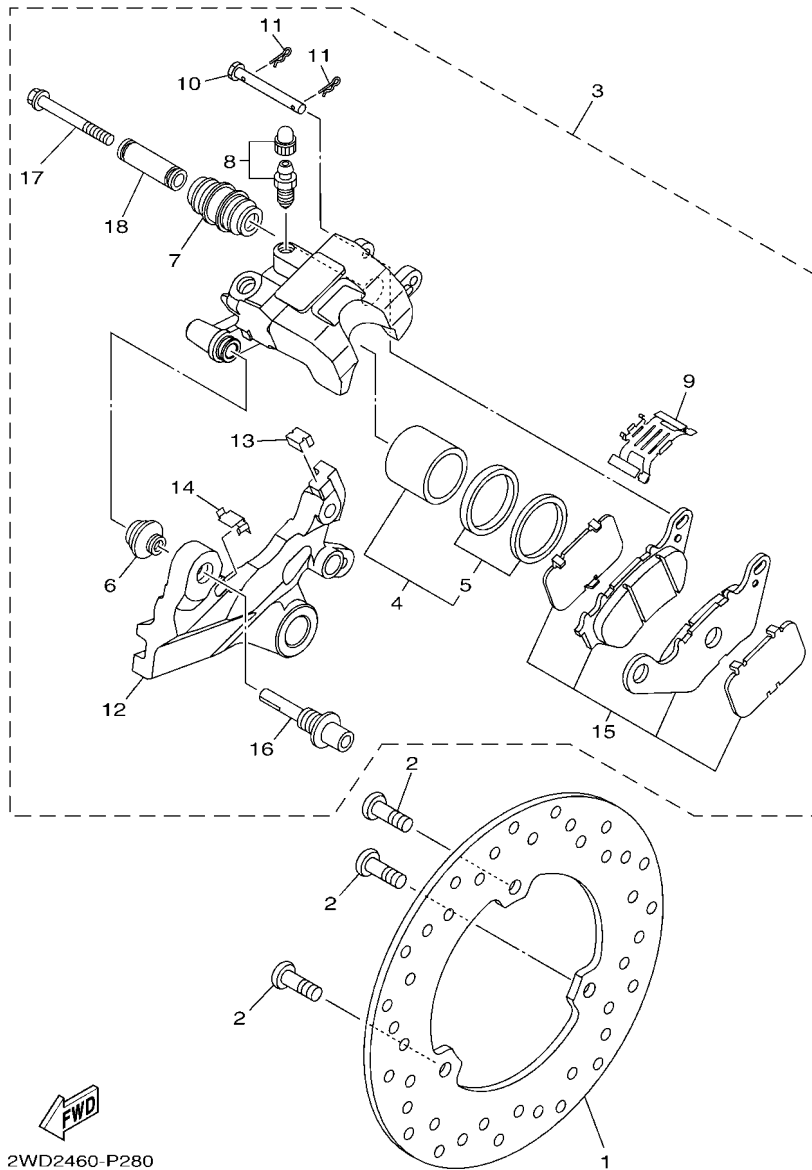
REF. NO.	PART NO.	DESCRIPTION	BFA1		REMARKS
1	BS7-F5338-10-P0	CAST WHEEL, REAR	1		DPBM15 FOR DPBMC
	BS7-F5338-10-98	CAST WHEEL, REAR	1		LGB FOR VOM2
2	90387-17810	COLLAR	1		
3	93306-20314	BEARING	2		
4	93106-23002	OIL SEAL	1		
5	1WD-F5364-00	DAMPER	6		
6	1WD-F5366-01-98	CLUTCH, HUB	1		UR LGB FOR VOM2
	1WD-F5366-01-P0	CLUTCH, HUB	1		UR FOR DPBMC
7	93306-30450	BEARING	1		
8	93106-38046	OIL SEAL	1		
9	1WD-F5377-00	COLLAR, WHEEL	1		
10	1WD-F5443-00	SPROCKET, DRIVEN (43T)	1		
11	1WD-F537W-00	BRACKET 1	1		
12	1WD-F537X-00	BRKT 2	1		
13	1WD-F539F-00	PLATE 1	3		
14	90116-10065	BOLT, STUD	6		
15	95602-10200	NUT, SELF-LOCKING	6		
16	94114-17802	TIRE (140/70-17M/C 66S RX-01R)	1		INOUE
17	93900-00828	VALVE, RIM	1		
18	5MT-25398-00	BALANCER, WHEEL (10G)	1		UN
	5MT-25398-10	BALANCER, WHEEL (20G)	1		UN
	5MT-25398-20	BALANCER, WHEEL (30G)	1		UN
19	2DP-F517G-00	ROTOR, SENSOR	1		
20	90149-05029	SCREW	3		
21	1WD-25381-00	AXLE, WHEEL	1		
22	1WD-F5386-00	COLLAR, SPROCKET AXLE	1		
23	1WD-F5383-00	COLLAR, WHEEL	1		



2WD2460-P271

FIG. 27 REAR WHEEL

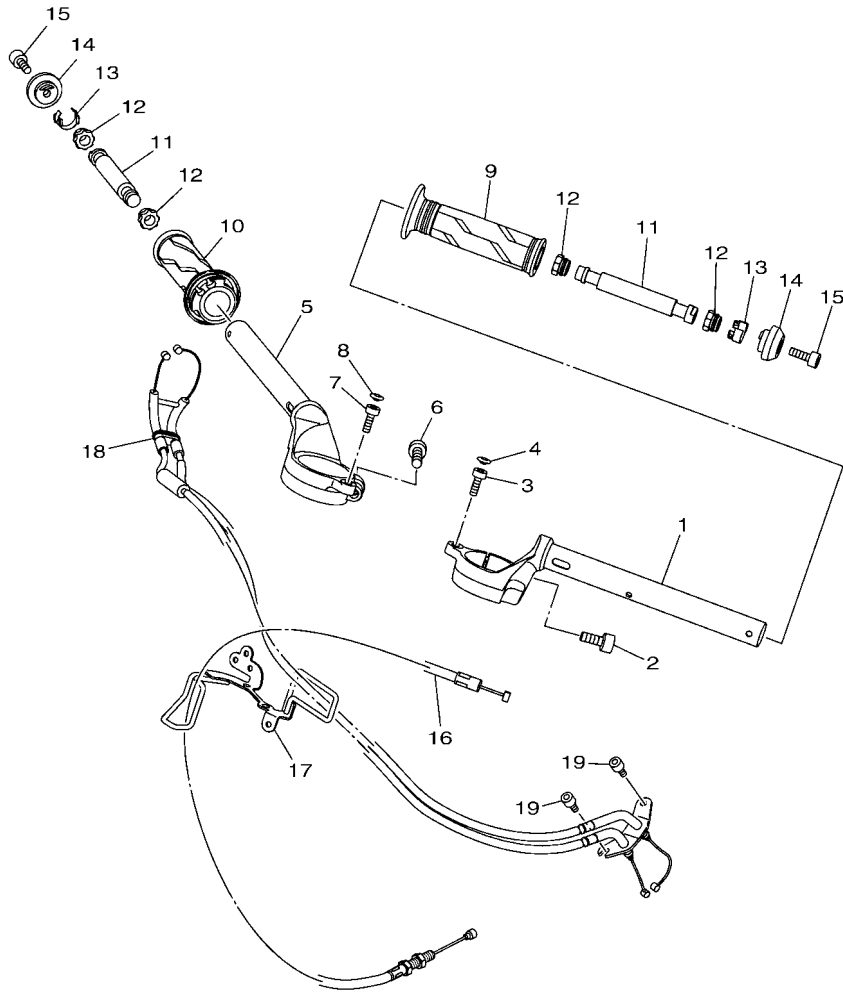
REF. NO.	PART NO.	DESCRIPTION	BFA1				REMARKS
24	95602-16200	NUT, SELF-LOCKING	1				
25	90201-17809	WASHER, PLATE	2				
26	1WD-F5388-00	PULLER, CHAIN 1	2				
27	1WD-F2174-00	END 1	2				
28	92902-08600	WASHER, PLATE	2				
29	95302-08600	NUT, HEXAGON	4				
30	40D-E443G-00	PIPE, DRAIN 2	2				
31	94568-H3112	CHAIN (DID520VF 112LE)	1				



2WD2460-P280

**FIG. 28 REAR BRAKE CALIPER**

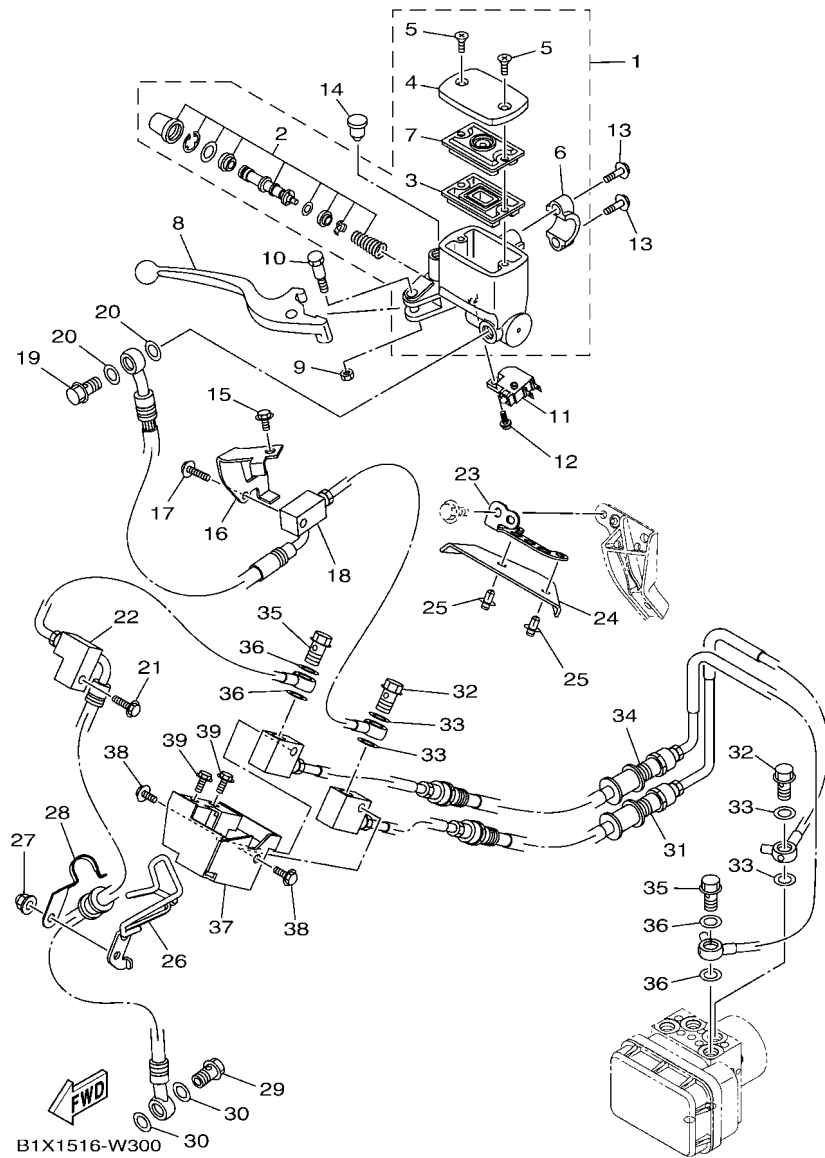
REF. NO.	PART NO.	DESCRIPTION	BFA1				REMARKS
1	1WD-F582W-00	DISK, REAR BRAKE 2	1				
2	90111-08087	BOLT, HEXAGON SOCKET BUTTON	3				
3	2WD-F580W-00	CALIPER ASSY, REAR 2	1				
4	1WD-25802-50	.PISTON ASSY, CALIPER	1				
5	1WD-25803-50	..CALIPER SEAL KIT	1				
6	5YP-F5917-00	.BOOT, CALIPER	1				
7	34X-25937-00	.BOOT 2	1				
8	5YP-W0048-50	.BLEED SCREW KIT	1				
9	1WD-F5919-50	.SUPPORT, PAD	1				
10	1WD-F5924-50	.PIN, PAD	1				
11	5YP-F5925-01	.CLIP	2				
12	2WD-F5921-50	.BRACKET, SUPPORT	1				
13	1WD-F5939-51	.CLIP, PAD	1				
14	1WD-F5939-61	.CLIP, PAD	1				
15	1WD-25806-00	.BRAKE PAD KIT 2	1				
16	1WD-F5914-50	.PIN, SLIDE	1				
17	5KN-25926-01	.BOLT	1				
18	5TL-F5838-00	.SLEEVE, CALIPER	1				



B1X1516-W290

FIG. 29 STEERING HANDLE & CABLE

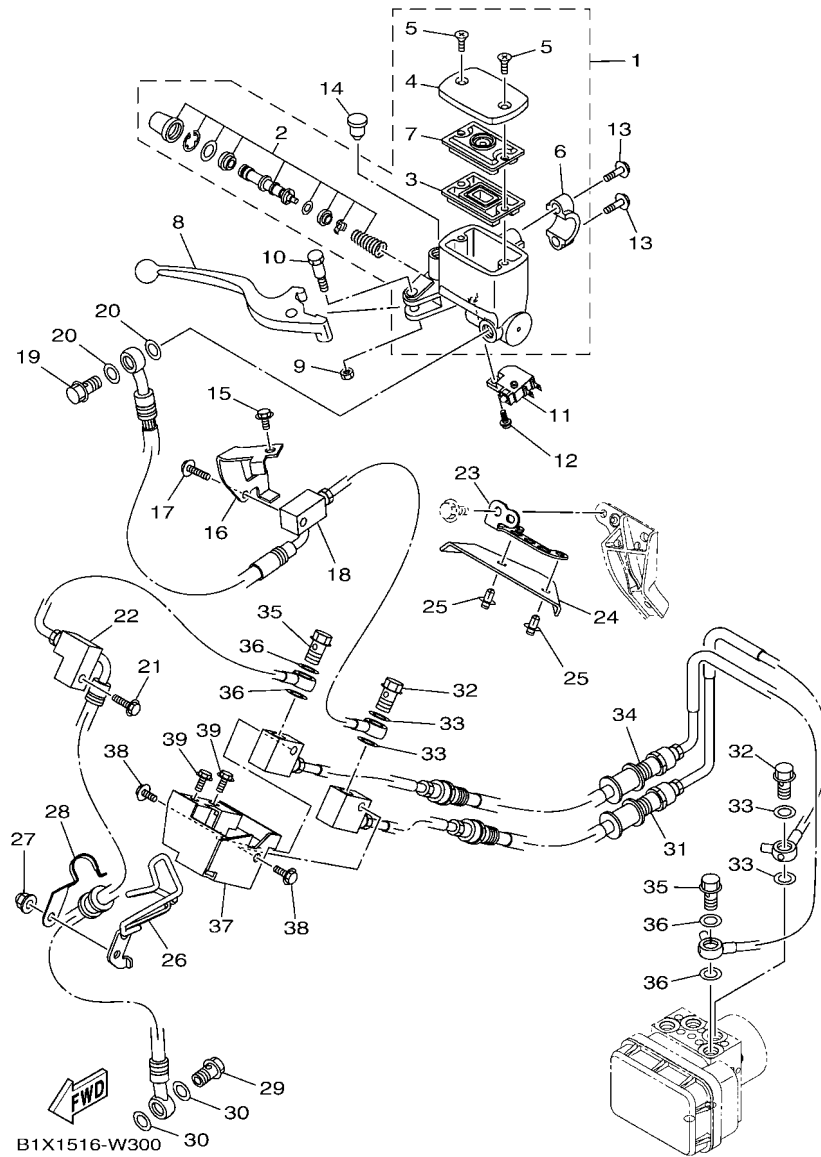
REF. NO.	PART NO.	DESCRIPTION	BFA1				REMARKS
1	BS7-F6121-00	HANDLEBAR (LEFT)	1				
2	91317-08020	BOLT, HEXAGON SOCKET HEAD	1				
3	91317-06016	BOLT, HEXAGON SOCKET HEAD	1				
4	20P-F3469-00	CAP, BOLT	1				
5	BS7-F6122-00	HANDLEBAR (RIGHT)	1				
6	91317-08020	BOLT, HEXAGON SOCKET HEAD	1				
7	91317-06016	BOLT, HEXAGON SOCKET HEAD	1				
8	20P-F3469-00	CAP, BOLT	1				
9	2DP-F6241-00	GRIP	1				
10	2DP-F6240-00	GRIP ASSY	1				
11	2MS-F622H-00	WEIGHT	2				
12	1S7-F622F-00	DAMPER, LOCATING 1	4				
13	1S7-F6257-00	STOPPER	2				
14	1WD-F6246-00	END, GRIP	2				
15	91317-06020	BOLT, HEXAGON SOCKET HEAD	2				
16	1WD-F6335-00	WIRE, CLUTCH	1				
17	BS7-F6131-00	GUIDE, CABLE 1	1				
18	B1X-F6301-00	THROTTLE CABLE ASSY	1				
19	91312-05010	BOLT, HEXAGON SOCKET HEAD	2				



**FIG. 30 FRONT MASTER CYLINDER**

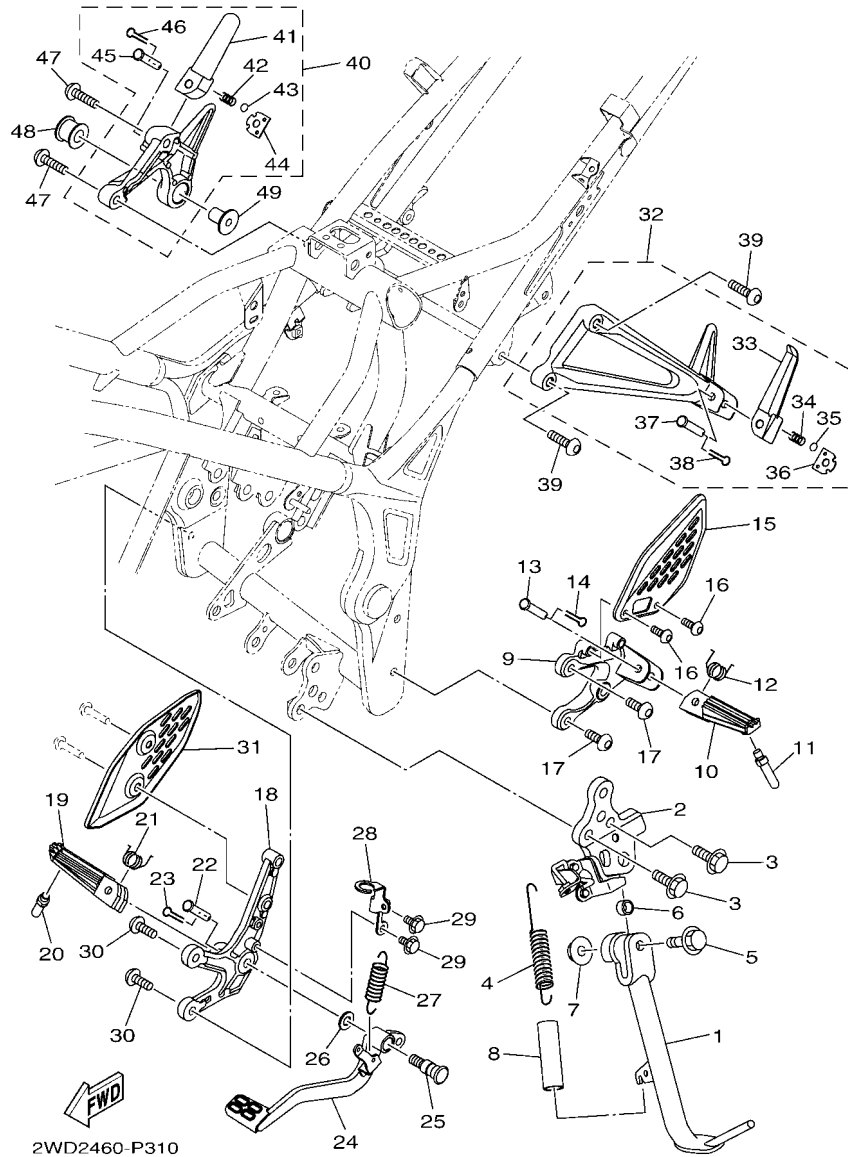
REF. NO.	PART NO.	DESCRIPTION	BFA1				REMARKS
1	1WD-F5870-00	MASTER CYLINDER SUB ASSY	1				
2	1WD-F5807-00	.CYLINDER KIT, MASTER	1				
3	5RB-25854-00	.DIAPHRAGM, RESERVOIR	1				
4	1WD-F5852-00	.CAP, RESERVOIR	1				
5	36Y-2589H-00	.SCREW	2				
6	3RW-F5867-00	.BRACKET, MASTER CYLINDER	1				
7	3C1-F5855-00	.BUSH,DIAPHRAGM	1				
8	1WD-H3922-00	LEVER 2	1				
9	95602-06100	NUT, SELF-LOCKING	1				
10	90109-06577	BOLT	1				
11	2DP-H3980-01	FRONT STOP SWITCH ASSY	1				
12	97602-04212	SCREW, PAN HEAD WITH WASHER	1				
13	95027-06025	BOLT, FLANGE	2				
14	90338-09803	PLUG	1				
15	95812-06012	BOLT, FLANGE	1				
16	2WD-F588F-00	HOLDER, BRAKE HOSE 5	1				
17	95022-06020	BOLT, FLANGE	1				
18	B5L-F5872-00	HOSE, BRAKE 1	1				
19	90401-10812	BOLT, UNION	1				
20	90201-10118	WASHER, PLATE	2				
21	95022-06020	BOLT, FLANGE	1				
22	B1X-F581J-00	HOSE, BRAKE 4	1				
23	B5L-F612E-00	BRACKET	1				
24	BS7-F3818-00	COVER, STEERING	1				
25	90269-06816	RIVET	2				
26	B6W-F5887-00	HOLDER, BRAKE HOSE 3	1				
27	90176-06065	NUT, CAP	1				

**FIG. 30 FRONT MASTER CYLINDER**



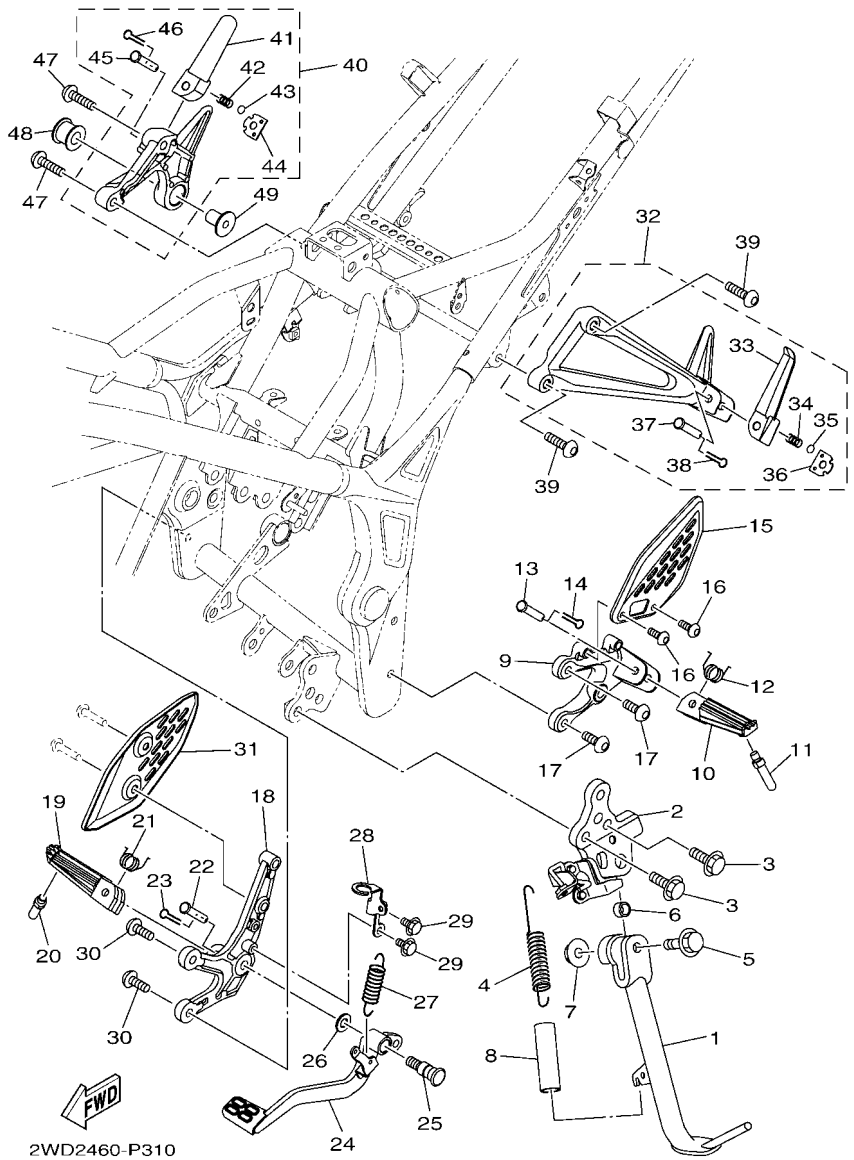
REF. NO.	PART NO.	DESCRIPTION	BFA1				REMARKS
28	B5L-F587A-00	HOLDER, BRAKE HOSE 4	1				
29	90401-10812	BOLT, UNION	1				
30	90201-10118	WASHER, PLATE	2				
31	2WD-F5873-00	HOSE, BRAKE 2	1				
32	90401-10812	BOLT, UNION	2				
33	90201-10118	WASHER, PLATE	4				
34	B5L-F5874-00	HOSE, BRAKE 3	1				
35	90401-10812	BOLT, UNION	2				
36	90201-10118	WASHER, PLATE	4				
37	2WD-F588G-01	HOLDER, BRAKE HOSE 6	1				
38	95027-06012	BOLT, FLANGE	2				
39	95027-06012	BOLT, FLANGE	2				





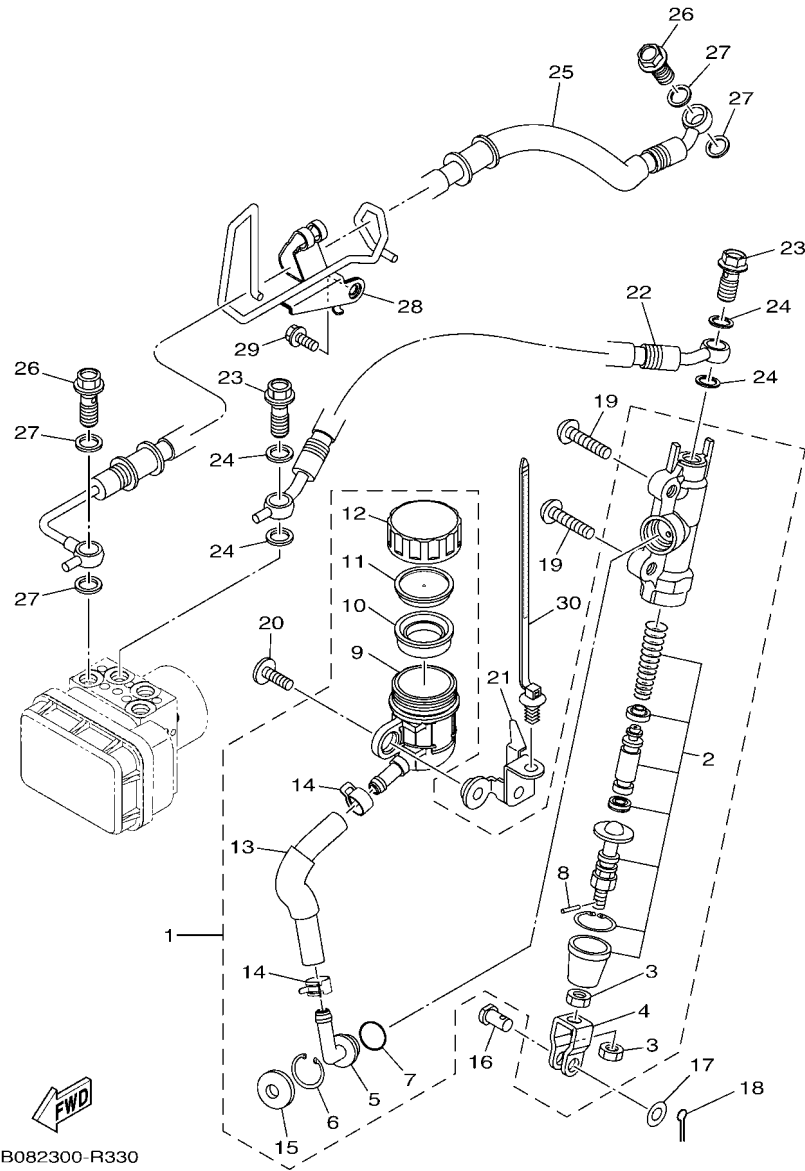
**FIG. 31 STAND & FOOTREST**

REF. NO.	PART NO.	DESCRIPTION	BFA1				REMARKS
1	1WD-F7311-00	STAND, SIDE	1				
2	1WD-F7321-10	BRACKET, SIDE STAND	1				
3	95817-10025	BOLT, FLANGE	2				
4	90506-23812	SPRING, TENSION	1				
5	90105-106A7	BOLT, FLANGE	1				
6	90387-10010	COLLAR	1				
7	95602-10200	NUT, SELF-LOCKING	1				
8	90445-217G3	HOSE (L70)	1				
9	1WD-F7442-01	BRACKET 2	1				
10	1WD-F7451-00	FOOTREST	1				
11	1WD-F7435-00	BOLT	1				
12	90508-183B9	SPRING, TORSION	1				
13	90240-08145	PIN, CLEVIS	1				
14	91401-25015	PIN, COTTER	1				
15	1WD-F7445-00	PLATE 1	1				
16	90111-06013	BOLT, HEXAGON SOCKET BUTTON	2				
17	90109-085G6	BOLT	2				
18	1WD-F7443-00	BRACKET 3	1				
19	1WD-F7461-00	FOOTREST	1				
20	1WD-F7435-00	BOLT	1				
21	90508-183B9	SPRING, TORSION	1				
22	90240-08145	PIN, CLEVIS	1				
23	91401-25015	PIN, COTTER	1				
24	1WD-F7211-00	PEDAL, BRAKE	1				
25	4BP-27261-00	SHAFT	1				
26	90201-10021	WASHER, PLATE	1				
27	90506-26807	SPRING, TENSION	1				



**FIG. 31 STAND & FOOTREST**

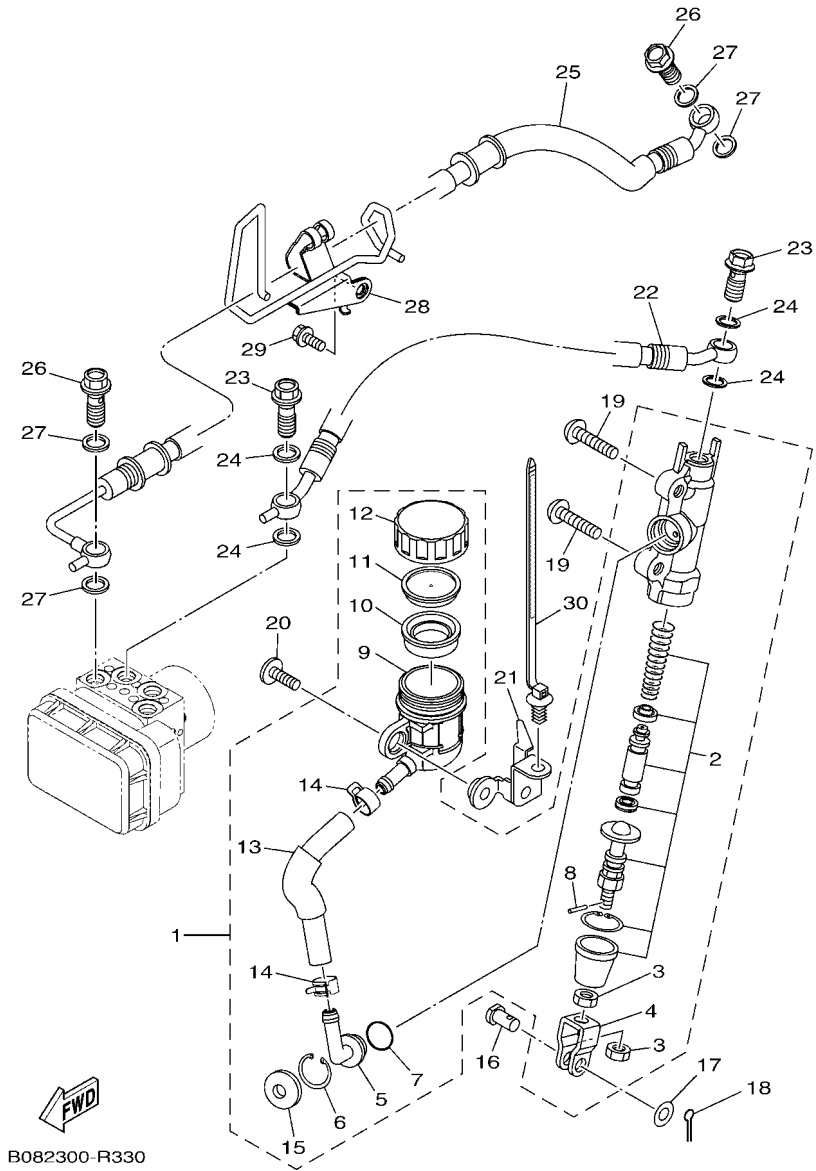
REF. NO.	PART NO.	DESCRIPTION	BFA1				REMARKS
28	1WD-F144G-00	STAY, STOP SWITCH	1				
29	95802-06010	BOLT, FLANGE	2				
30	90109-085G6	BOLT	2				
31	1WD-F7446-00	PLATE 2	1				
32	1WD-F7430-01	REAR FOOTREST ASSY 1	1				
33	1WD-F7431-01	.FOOTREST, REAR 1	1				
34	90501-12743	.SPRING, COMPRESSION	1				
35	93501-04830	.BALL	1				
36	1WD-F7437-00	.WASHER, SPECIAL	1				
37	90240-08145	.PIN, CLEVIS	1				
38	91401-25015	.PIN, COTTER	1				
39	90110-08071	BOLT, HEXAGON SOCKET HEAD	2				
40	1WD-F7440-01	REAR FOOTREST ASSY 2	1				
41	1WD-F7441-01	.FOOTREST, REAR 2	1				
42	90501-12743	.SPRING, COMPRESSION	1				
43	93501-04830	.BALL	1				
44	1WD-F7437-00	.WASHER, SPECIAL	1				
45	90240-08145	.PIN, CLEVIS	1				
46	91401-25015	.PIN, COTTER	1				
47	90110-08071	BOLT, HEXAGON SOCKET HEAD	2				
48	5TP-E4747-00	DAMPER, MUFFLER	1				
49	90387-08813	COLLAR	1				



B082300-R330

FIG. 32 REAR MASTER CYLINDER

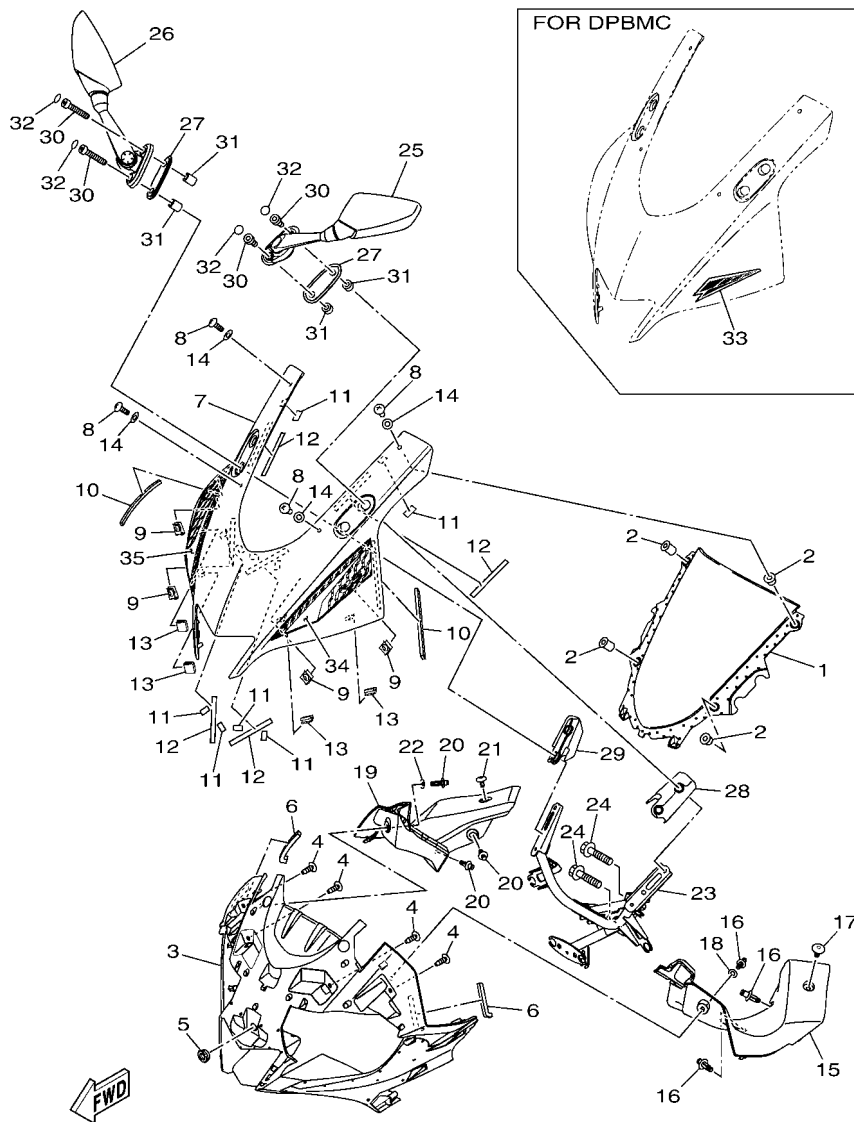
REF. NO.	PART NO.	DESCRIPTION	BFA1				REMARKS
1	1WD-F580E-00	REAR MASTER CYLINDER ASSY	1				
2	1WD-F5808-00	.CYLINDER KIT, MASTER	1				
3	4SS-27218-00	.NUT	2				
4	50C-F7222-00	.JOINT	1				
5	50C-F582A-50	.JOINT	1				
6	50C-F5866-00	.CIRCLIP	1				
7	93210-15620	.O-RING	1				
8	3KW-27234-00	.PIN, BRAKE ROD	1				
9	50C-F5894-10	.TANK, RESERVOIR	1				
10	2VN-F5854-00	.DIAPHRAGM, RESERVOIR	1				
11	50C-F5855-00	.BUSH,DIAPHRAGM	1				
12	1WD-F5852-50	.CAP, RESERVOIR	1				
13	1WD-F5895-50	.HOSE, RESERVOIR	1				
14	90467-12085	.CLIP	2				
15	50C-F589A-00	.COVER, DUST	1				
16	90240-08124	PIN, CLEVIS	1				
17	90201-08083	WASHER, PLATE	1				
18	91401-20012	PIN, COTTER	1				
19	92012-08030	BOLT, BUTTON HEAD	2				
20	90111-06121	BOLT, HEXAGON SOCKET BUTTON	1				
21	B04-F582E-00	HOLDER, RESERVE TANK	1				
22	2WD-F581K-00	HOSE, BRAKE 5	1				
23	90401-10812	BOLT, UNION	2				
24	90201-10118	WASHER, PLATE	4				
25	2WD-F582J-00	HOSE, BRAKE 6	1				
26	90401-10812	BOLT, UNION	2				
27	90201-10118	WASHER, PLATE	4				



B082300-R330

**FIG. 32 REAR MASTER CYLINDER**

REF. NO.	PART NO.	DESCRIPTION	BFA1	REMARKS
28	2WD-F5887-00	HOLDER, BRAKE HOSE	1	
29	95D37-06014	BOLT, FLANGE DEEP RECESS	1	
30	90464-30009	CLAMP	1	
<hr style="border-top: 1px dashed black;"/>				
<hr style="border-top: 1px dashed black;"/>				
<hr style="border-top: 1px dashed black;"/>				
<hr style="border-top: 1px dashed black;"/>				
<hr style="border-top: 1px dashed black;"/>				
<hr style="border-top: 1px dashed black;"/>				
<hr style="border-top: 1px dashed black;"/>				
<hr style="border-top: 1px dashed black;"/>				
<hr style="border-top: 1px dashed black;"/>				
<hr style="border-top: 1px dashed black;"/>				
<hr style="border-top: 1px dashed black;"/>				
<hr style="border-top: 1px dashed black;"/>				

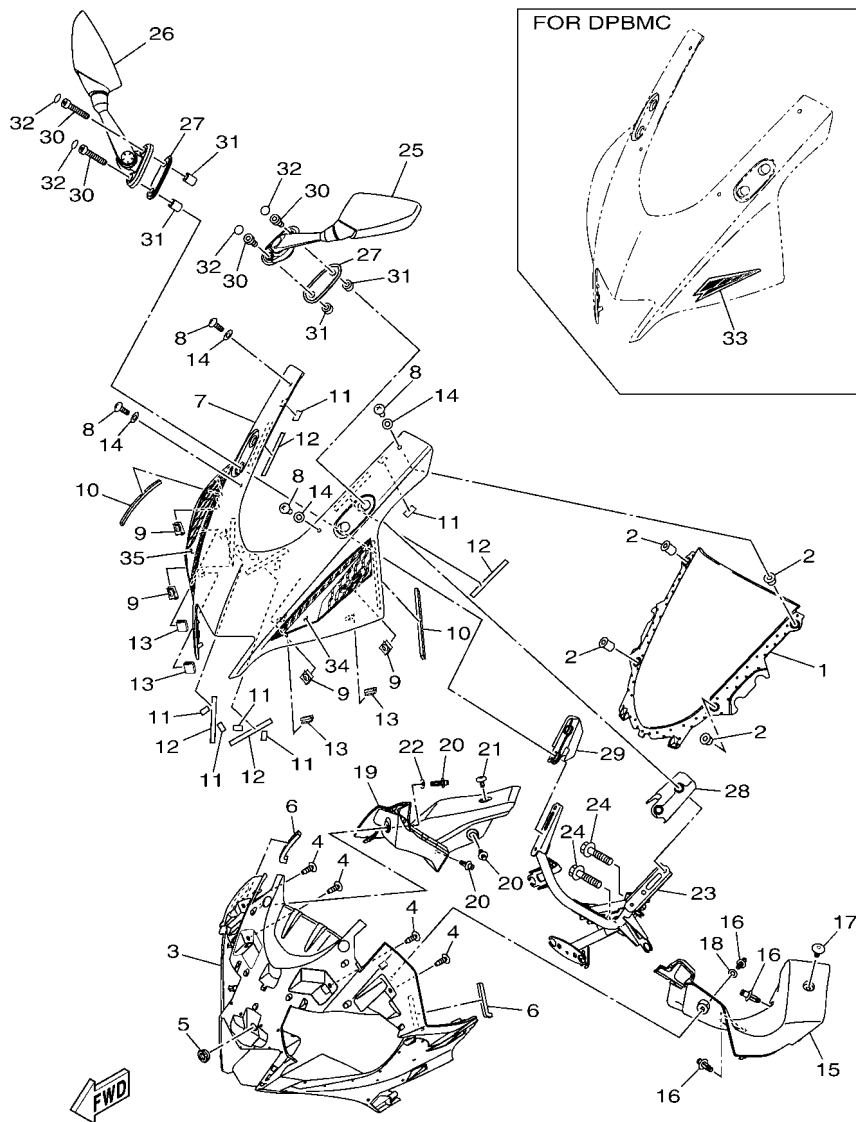


BFA1440-Y330

FIG. 33 WINDSHIELD

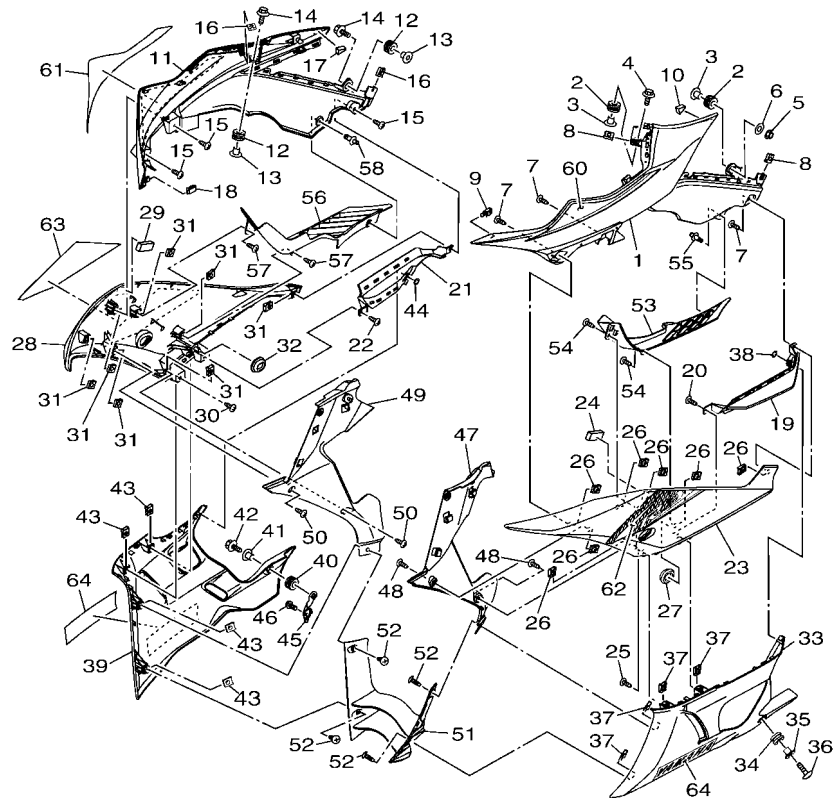
REF. NO.	PART NO.	DESCRIPTION	BFA1	REMARKS
1	BS7-F8381-00	WINDSHIELD	1	
2	90179-05849	NUT	4	
3	BS7-F835G-00	BODY, FRONT UPPER 1	1	
4	97702-50016	SCREW, TAPPING	4	
5	90480-13398	GROMMET	1	
6	90520-07808	DAMPER, PLATE	2	
7	BS7-F8351-00-P0	BODY, COWLING	1	UR FOR DPBMC
	BS7-F8351-00-P8	COWLING	1	UR FOR VOM2
8	90150-05023	SCREW, ROUND HEAD	4	
9	90183-05807	NUT, SPRING	4	
10	90520-07808	DAMPER, PLATE	2	
11	31B-F8307-00	SEAL	6	
12	1WD-F414E-00	SEAL 2	4	
13	1WD-F8376-00	TRIM	4	
14	90202-05088	WASHER, PLATE	4	
15	BS7-F836N-00	PANEL, INNER 4	1	
16	90269-06816	RIVET	3	
17	90111-05003	BOLT, HEXAGON SOCKET BUTTON	1	
18	BS7-F8327-00	DAMPER, LEG SHIELD	1	
19	BS7-F836R-00	PANEL, INNER 5	1	
20	90269-06816	RIVET	3	
21	90111-05003	BOLT, HEXAGON SOCKET BUTTON	1	
22	BS7-F8327-00	DAMPER, LEG SHIELD	1	
23	BS7-F8356-00	STAY 1	1	
24	95812-08035	BOLT, FLANGE	2	
25	BS7-F6280-00	REAR VIEW MIRROR ASSY (LEFT)	1	
26	BS7-F6290-00	REAR VIEW MIRROR ASSY (RIGHT)	1	

**FIG. 33 WINDSHIELD**



BFA1440-Y330

REF. NO.	PART NO.	DESCRIPTION	BFA1				REMARKS
27	BK6-F8483-00	PLATE, RUBBER 1	2				
28	BS7-F8484-00	PLATE, RUBBER 2	1				
29	BS7-F8485-00	PLATE, RUBBER 3	1				
30	91317-06030	BOLT, HEXAGON SOCKET HEAD	4				
31	90387-06131	COLLAR	4				
32	90338-05010	PLUG	4				
33	B5L-F8391-20	GRAPHIC 1	1				UR FOR DPBMC
	B5P-F8391-00	GRAPHIC 1	1				UR FOR VOM2
34	B5L-F8392-30	GRAPHIC 2	1				FOR VOM2



BFA1440-Y340

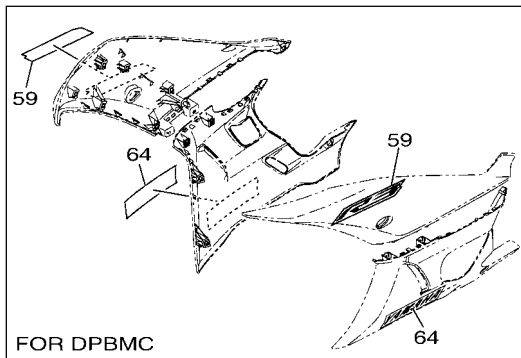
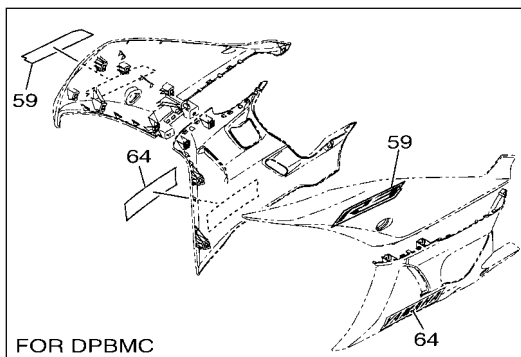
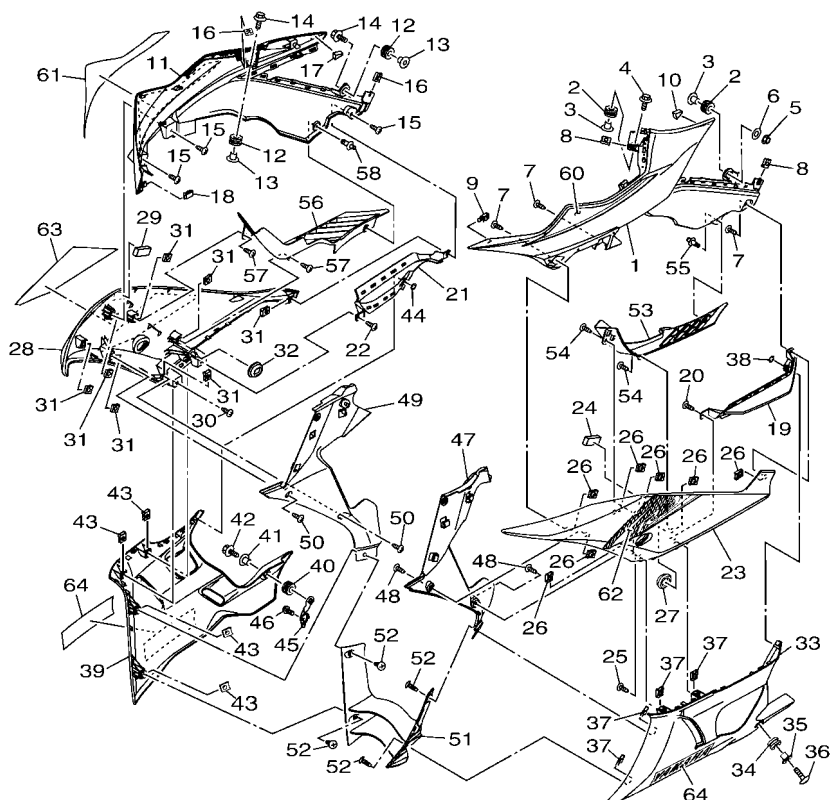


FIG. 34 COWLING 1

REF. NO.	PART NO.	DESCRIPTION	BFA1	REMARKS
1	BS7-F172G-00-P0	PANEL 3	1	UR FOR DPBMC
	BS7-F172G-00-P5	PANEL 3	1	UR MNM3 FOR VOM2
2	90480-12808	GROMMET	2	
3	90387-06899	COLLAR	2	
4	90119-06810	BOLT, WITH WASHER	1	
5	95702-06500	NUT, FLANGE	1	
6	90201-06380	WASHER PLAIN	1	
7	97702-50016	SCREW, TAPPING	3	
8	90183-050A7	NUT, SPRING	2	
9	44D-F8379-00	HOOK	1	
10	BS7-F8415-00	DAMPER 1	1	
11	BS7-F172H-00-P0	PANEL 4	1	UR FOR DPBMC
	BS7-F172H-00-P5	PANEL 4	1	UR MNM3 FOR VOM2
12	90480-12808	GROMMET	2	
13	90387-06899	COLLAR	2	
14	90119-06810	BOLT, WITH WASHER	2	
15	97702-50016	SCREW, TAPPING	3	
16	90183-050A7	NUT, SPRING	2	
17	BS7-F8415-00	DAMPER 1	1	
18	44D-F8379-00	HOOK	1	
19	BS7-F117V-00	COVER 7	1	
20	97702-50016	SCREW, TAPPING	1	
21	BS7-F117W-00	COVER 8	1	
22	97702-50016	SCREW, TAPPING	1	
23	BS7-F835U-00-P9	PANEL 1	1	UR MBM3 FOR DPBMC
	BS7-F835U-00-P2	PANEL 1	1	UR MNM3 FOR VOM2
24	5YT-24665-00	DAMPER	1	

**FIG. 34 COWLING 1**

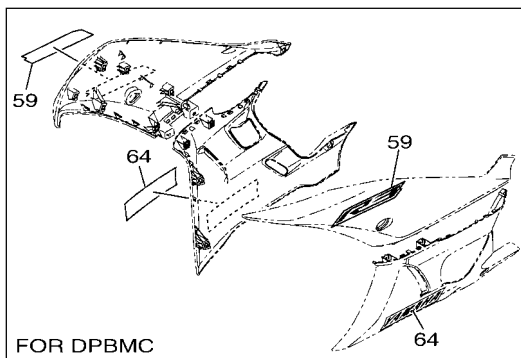
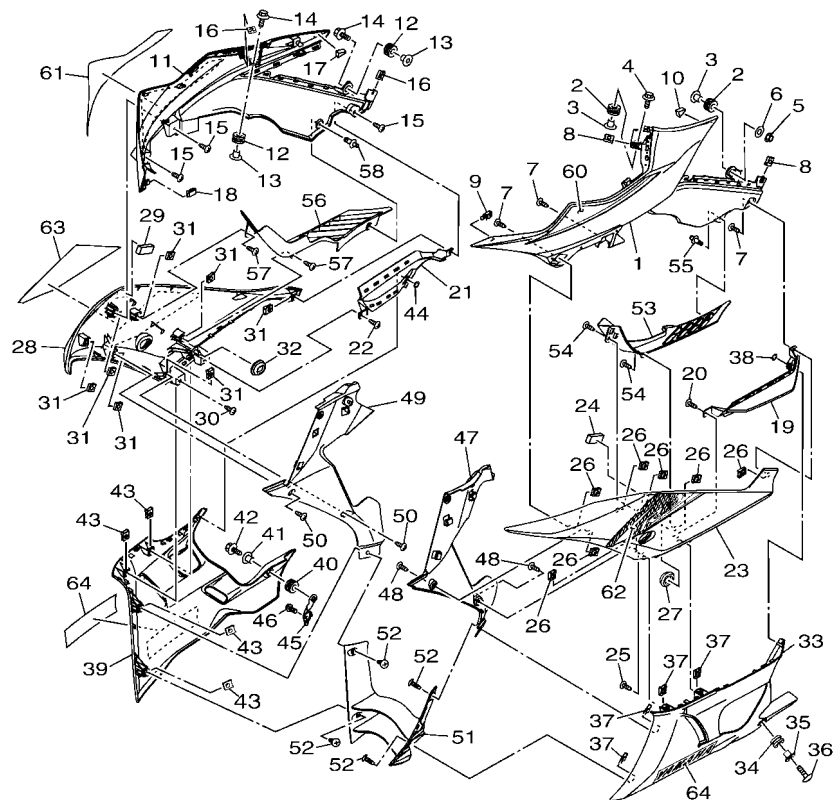


**FWD**  
BFA1440-Y340

REF. NO.	PART NO.	DESCRIPTION	BFA1	REMARKS
25	97702-50016	SCREW,TAPPING	1	
26	90183-05807	NUT, SPRING	7	
27	90480-01821	GROMMET	1	
28	BS7-F835V-00-P9	PANEL 2	1	UR MBM3 FOR DPBMC
	BS7-F835V-00-P2	PANEL 2	1	UR MNM3 FOR VOM2
29	5YT-24665-00	DAMPER	1	
30	97702-50016	SCREW,TAPPING	1	
31	90183-05807	NUT, SPRING	7	
32	90480-01821	GROMMET	1	
33	BS7-F8385-00-P9	COVER, UNDER	1	UR MBM3 FOR DPBMC
	BS7-F8385-00-P2	COVER, UNDER	1	UR MNM3 FOR VOM2
34	90480-12808	GROMMET	1	
35	90387-06899	COLLAR	1	
36	90111-06117	BOLT, HEXAGON SOCKET BUTTON	1	
37	90183-05807	NUT, SPRING	4	
38	90183-05M02	NUT, SPRING	1	
39	B1X-F8395-00-P3	COVER, UNDER 2	1	UR MBM3 FOR DPBMC
	B1X-F8395-00-P2	COVER, UNDER 2	1	UR MNM3 FOR VOM2
40	90480-12808	GROMMET	1	
41	90387-06899	COLLAR	1	
42	90111-06117	BOLT, HEXAGON SOCKET BUTTON	1	
43	90183-05807	NUT, SPRING	4	
44	90183-05M02	NUT, SPRING	1	
45	BS7-F833E-00	BRACKET 8	1	
46	95022-06012	BOLT, FLANGE	1	
47	BS7-F836K-00	PANEL, INNER 1	1	
48	97707-50016	SCREW, TRUSS HEAD TAPPING	2	



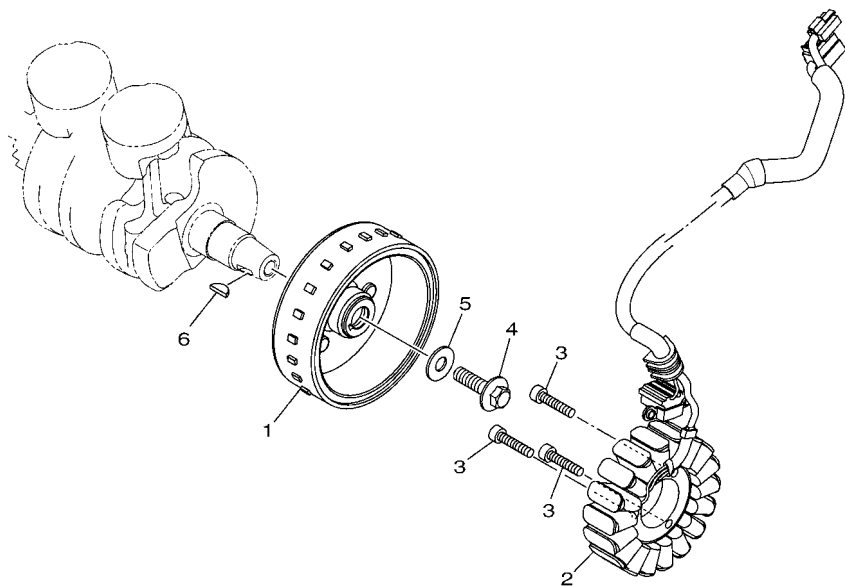
**FIG. 34 COWLING 1**



  
BFA1440-Y340

REF. NO.	PART NO.	DESCRIPTION	BFA1	REMARKS
49	BS7-F836L-00	PANEL, INNER 2	1	
50	97707-50016	SCREW, TRUSS HEAD TAPPING	2	
51	B1X-F836M-00	PANEL, INNER 3	1	
52	97707-50016	SCREW, TRUSS HEAD TAPPING	4	
53	BS7-F837V-00	GRILL, AIR OUTLET 1	1	
54	97702-50016	SCREW, TAPPING	2	
55	90269-06816	RIVET	1	
56	BS7-F837W-00	GRILL, AIR OUTLET 2	1	
57	97702-50016	SCREW, TAPPING	2	
58	90269-06816	RIVET	1	
59	B5P-F8393-00	GRAPHIC 3	2	UR FOR DPBMC
60	B5L-F8393-40	GRAPHIC 3	1	FOR VOM2
61	B5L-F8394-40	GRAPHIC 4	1	FOR VOM2
62	B5P-F8398-00	GRAPHIC 5	1	FOR VOM2
63	B5P-F8399-00	GRAPHIC 6	1	FOR VOM2
64	1WD-F8328-A0	EMBLEM	2	UR FOR DPBMC
	1WD-F8328-60	EMBLEM	2	UR FOR VOM2

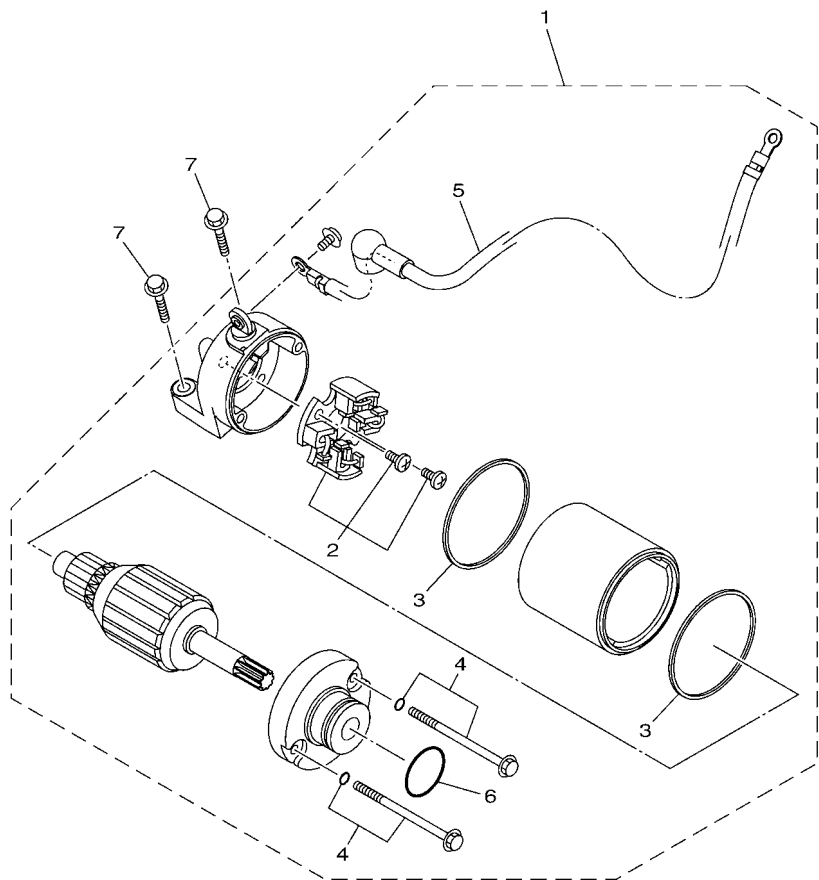
**FIG. 35 GENERATOR**



REF. NO.	PART NO.	DESCRIPTION	BFA1					REMARKS
1	BR5-H1450-00	ROTOR ASSY	1					
2	BS7-H1410-00	STATOR ASSY	1					
3	90110-06177	BOLT, HEXAGON SOCKET HEAD	3					
4	90105-10883	BOLT, FLANGE	1					
5	90201-10848	WASHER, PLATE	1					
6	90280-05013	KEY, WOODRUFF	1					

  
B6P2516-U350

**FIG. 36 STARTING MOTOR**



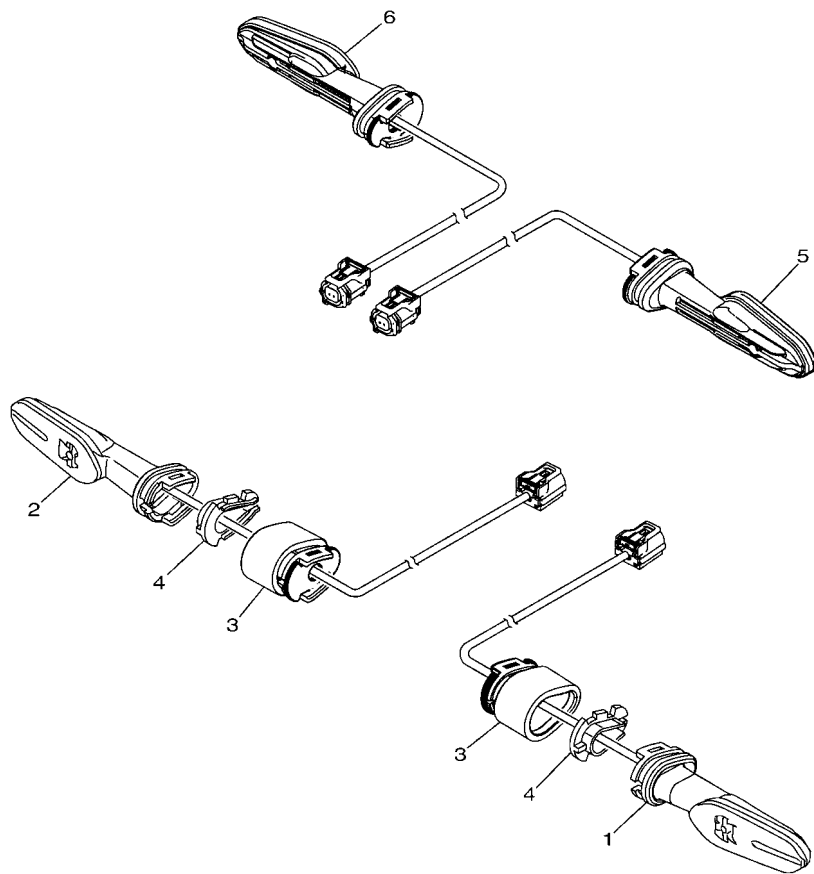
REF. NO.	PART NO.	DESCRIPTION	BFA1				REMARKS
1	1WD-H1800-01	STARTING MOTOR ASSY	1				
2	B74-H1801-00	.BRUSH SET	1				
3	1WD-H1861-00	.GASKET	2				
4	1WD-H1828-00	.BOLT 2	2				
5	1WD-H183G-00	.CORD COMP.	1				
6	4FP-H182L-00	.O-RING 1	1				
7	95022-06025	BOLT, FLANGE	2				



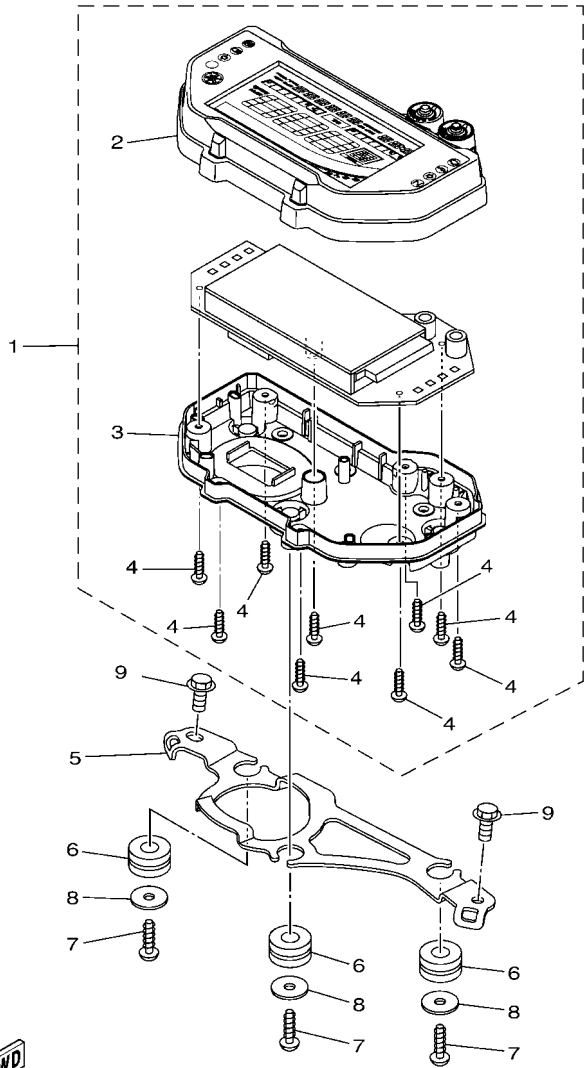
1WD1460-P360

**FIG. 37 FLASHER LIGHT**

REF. NO.	PART NO.	DESCRIPTION	BFA1				REMARKS
1	B1X-H330A-00	FLASHER LIGHT ASSY A	1				
2	B1X-H330A-00	FLASHER LIGHT ASSY A	1				
3	B1X-H338V-00	DAMPER	2				
4	B1X-H3318-00	STAY, FLASHER 1	2				
5	B1X-H330A-10	FLASHER LIGHT ASSY A	1				
6	B1X-H330B-00	FLASHER LIGHT ASSY B	1				



B1X1516-W370

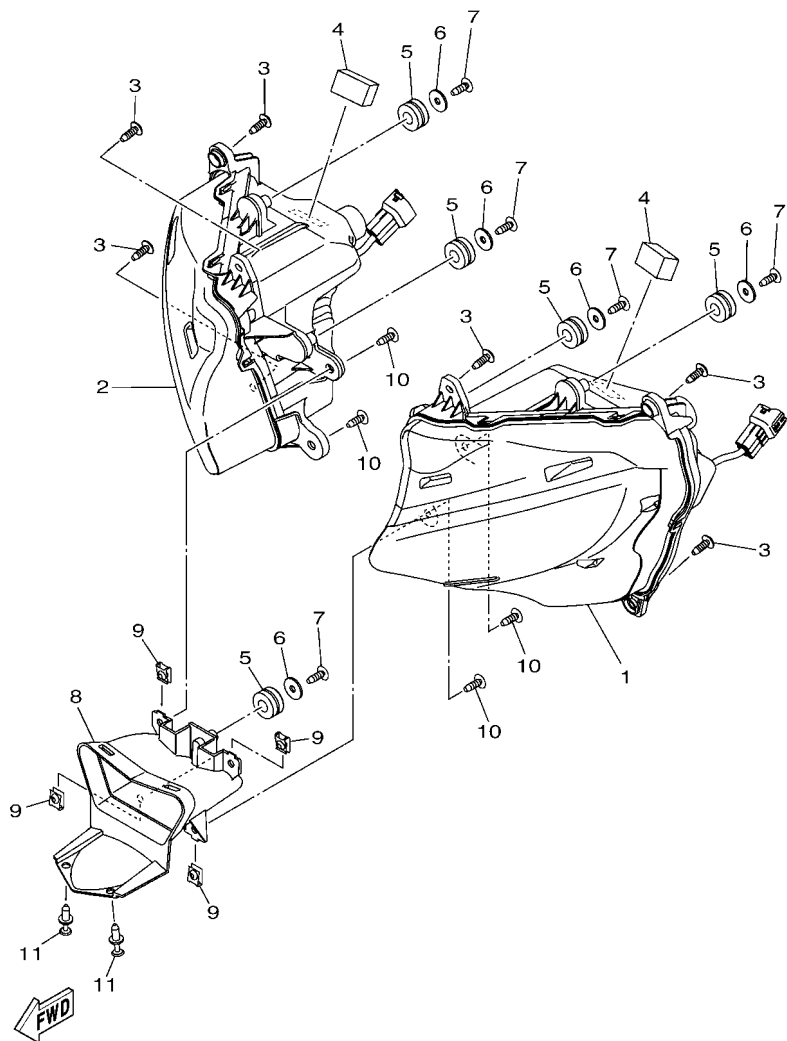


B1X1516-W380

FIG. 38 METER

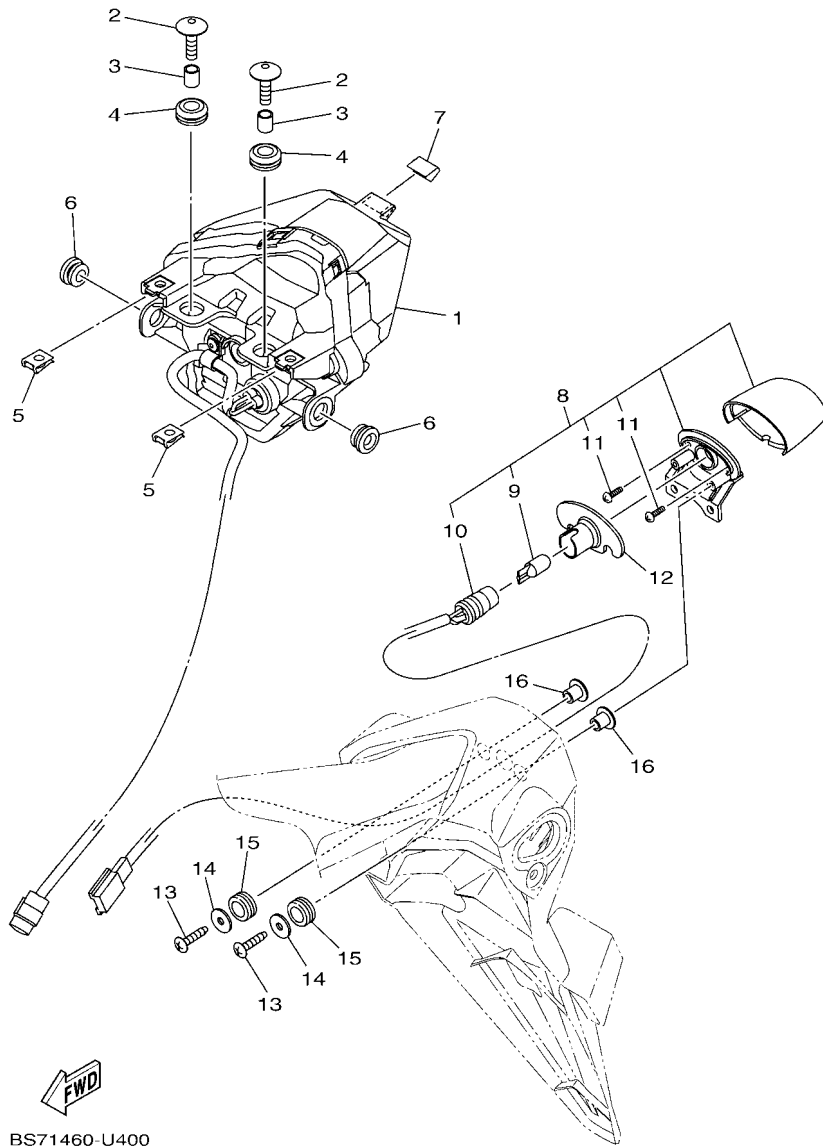
REF. NO.	PART NO.	DESCRIPTION	BFA1				REMARKS
1	B1X-H3500-01	METER ASSY	1				
2	B5P-H3571-01	.CASE, SPEEDOMETER UPPER	1				
3	BS7-H3572-01	.CASE, SPEEDOMETER LOWER	1				
4	97707-30020	.SCREW, TAPPING	9				
5	B1X-H3519-00	BRACKET, METER	1				
6	90480-14229	GROMMET	3				
7	97702-50016	SCREW, TAPPING	3				
8	90201-05827	WASHER, PLATE	3				
9	95022-06012	BOLT, FLANGE	2				

**FIG. 39 HEADLIGHT**



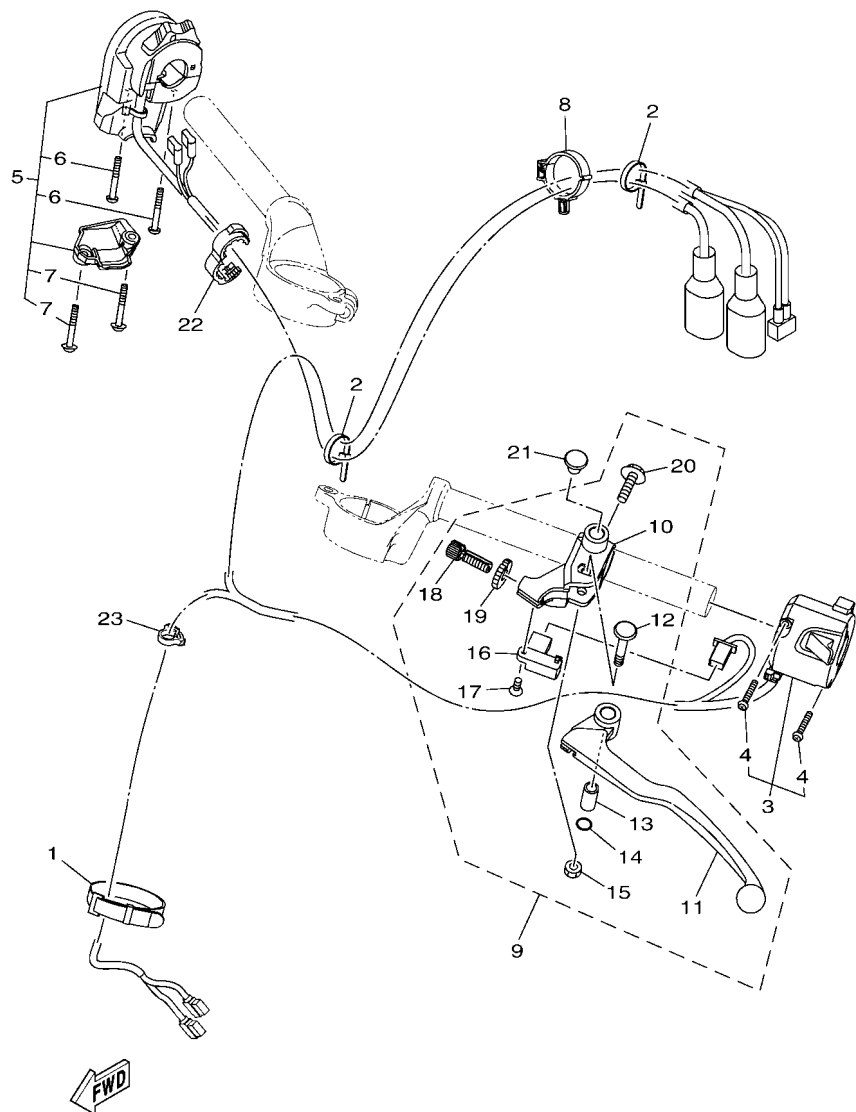
BS71460-U390

REF. NO.	PART NO.	DESCRIPTION	BFA1				REMARKS
1	BS7-H4300-00	HEADLIGHT ASSY	1				
2	BS7-H4300-10	HEADLIGHT ASSY	1				
3	97702-50016	SCREW,TAPPING	6				
4	90520-20825	DAMPER, PLATE	2				
5	90480-14229	GROMMET	5				
6	90201-05036	WASHER, PLATE	5				
7	97702-50016	SCREW,TAPPING	5				
8	BS7-F838N-00	DUCT 1	1				
9	90183-05807	NUT, SPRING	4				
10	97702-50016	SCREW,TAPPING	4				
11	90269-05005	RIVET	2				



**FIG. 40 TAILLIGHT**

REF. NO.	PART NO.	DESCRIPTION	BFA1				REMARKS
1	1WD-H4710-02	TAILLIGHT UNIT ASSY	1				
2	90111-06117	BOLT, HEXAGON SOCKET BUTTON	2				
3	90387-067V1	COLLAR	2				
4	90480-13001	GROMMET	2				
5	90183-05807	NUT, SPRING	2				
6	90480-10003	GROMMET	2				
7	1WD-F1732-00	SEAL 1	1				
8	BS7-H4740-10	LICENSE LIGHT ASSY	1				
9	1WD-H4744-00	.BULB (12V-5W)	1				
10	BS7-H4547-00	.CORD, LICENSE LIGHT	1				
11	1WD-H4726-00	.SCREW	2				
12	1WD-H4753-00	DAMPER	1				
13	97707-40020	SCREW, TAPPING	2				
14	90201-04804	WASHER, PLATE	2				
15	90480-11009	GROMMET	2				
16	90387-05042	COLLAR	2				



B1X1516-W410

FIG. 41 HANDLE SWITCH & LEVER

REF. NO.	PART NO.	DESCRIPTION	BFA1				REMARKS
1	3AY-H3936-00	BAND, SWITCH CORD	1				
2	90464-36005	CLAMP	2				
3	BS7-H3972-00	SWITCH, HANDLE 4	1				
4	98507-04025	.SCREW, PAN HEAD	2				
5	B1X-H3975-01	SWITCH, HANDLE 2	1				
6	98507-04030	.SCREW, PAN HEAD	2				
7	97607-05220	.SCREW, WITH WASHER	2				
8	90464-30001	CLAMP	1				
9	1WD-H2910-00	LEVER HOLDER ASSY (LEFT)	1				
10	1WD-H2911-00	.HOLDER, LEVER 1	1				
11	1WD-H3912-00	.LEVER 1	1				
12	31A-83945-00	.BOLT, LEVER	1				
13	31A-83913-00	.COLLAR, LEVER 1	1				
14	93210-108H5	.O-RING	1				
15	95602-06100	.NUT, SELF-LOCKING	1				
16	5BP-H2917-00	.SWITCH	1				
17	90151-03005	.SCREW, COUNTERSUNK	1				
18	90123-08083	.BOLT	1				
19	90179-08316	.NUT	1				
20	97507-06525	.BOLT, WITH WASHER	1				
21	90338-09803	PLUG	1				
22	90464-13227	CLAMP	1				
23	90464-22800	CLAMP	1				



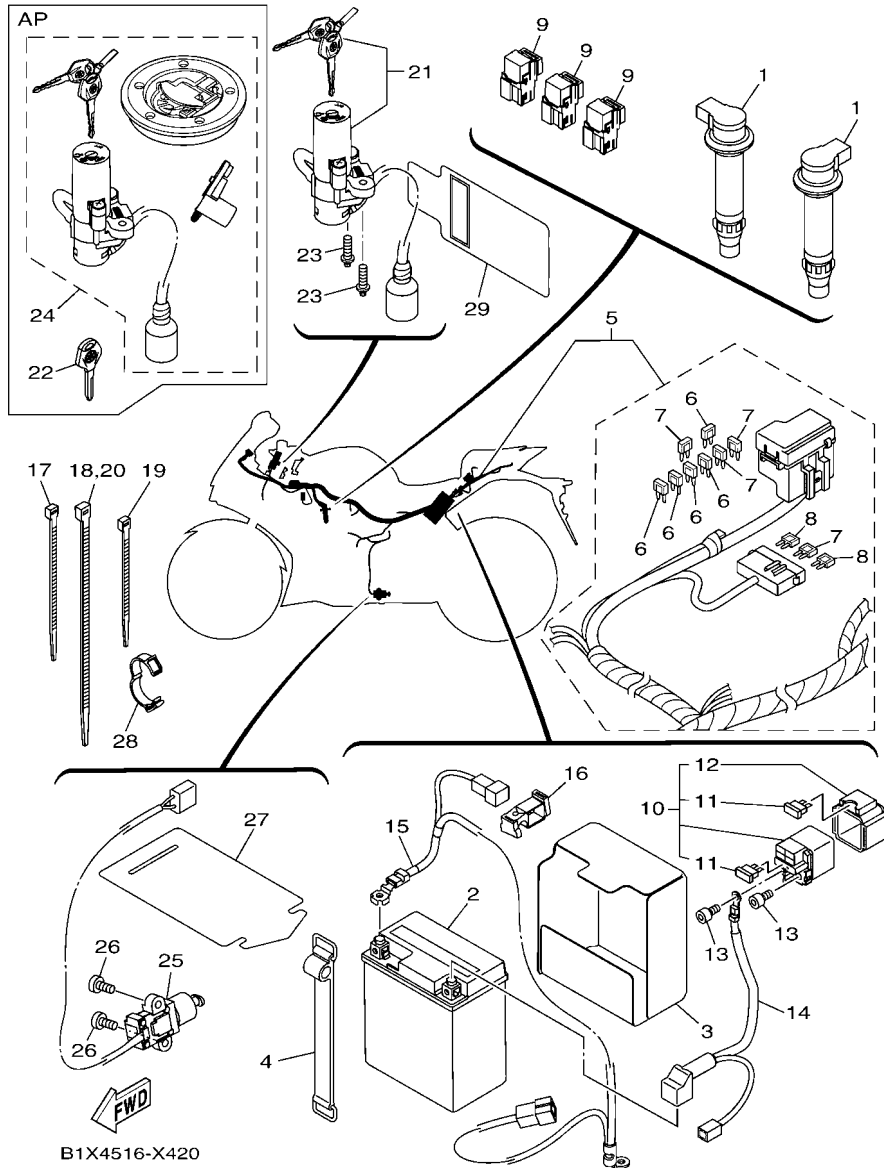


FIG. 42 ELECTRICAL 1

REF. NO.	PART NO.	DESCRIPTION	BFA1				REMARKS
1	B1X-82310-00	IGNITION COIL ASSY	2				
2	2YD-H2100-00	BATTERY ASSY (GS GTZ8V)	1				
3	1WD-H2121-00	PAD, BATTERY	1				
4	1WD-H2131-00	BAND, BATTERY	1				
5	B1X-H2590-00	WIRE HARNESS ASSY	1				
6	1WD-H2151-20	.FUSE (7.5A BL)	5				
7	1WD-H2151-10	.FUSE (15A-BL)	4				
8	1WD-H2151-30	.FUSE (30A)	2				
9	1WD-H1950-00	RELAY ASSY	3				
10	1WD-H1940-00	STARTER RELAY ASSY	1				
11	1WD-H2151-01	.FUSE (30A)	2				
12	1WD-H2155-00	.BAND	1				
13	91312-05008	BOLT, HEXAGON SOCKET HEAD	2				
14	2WD-H2115-01	WIRE, PLUS LEAD	1				
15	B6W-H2116-00	WIRE, MINUS LEAD	1				
16	BR5-H2592-00	BAND	1				
17	90464-36800	CLAMP	2				
18	90464-70800	CLAMP	7				
19	90464-22800	CLAMP	1				
20	90464-70800	CLAMP	1				
21	B1X-H2501-00	MAIN SWITCH STEERING LOCK	1				
22	1WD-H2511-09	BLANK KEY	1				AP
23	90109-060G4	BOLT	2				
24	B1X-XH250-00	MAIN SW. STRG. LOCK SUB ASSY	1				AP
25	1WD-H2566-01	SWITCH, SIDE STAND	1				
26	90110-05809	BOLT, HEXAGON SOCKET HEAD	2				
27	1WD-H2591-00	BAND	1				

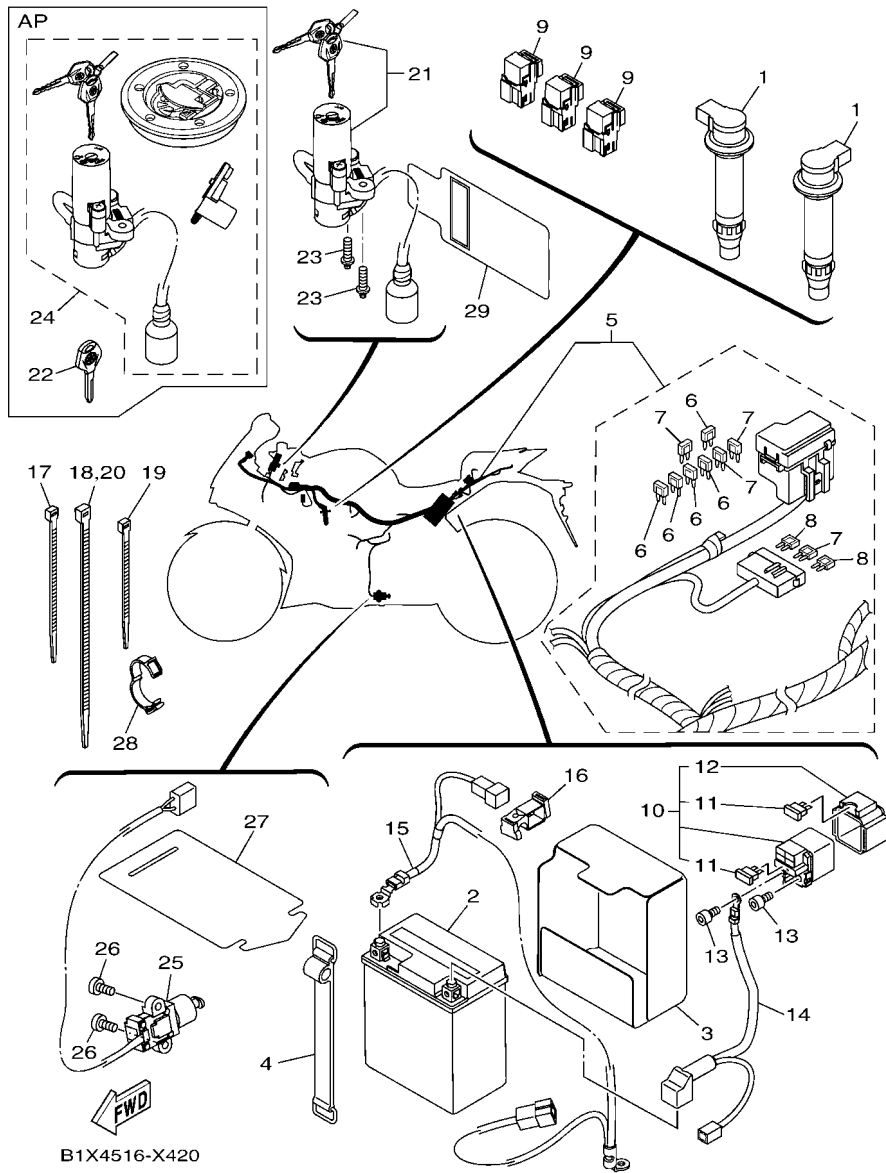
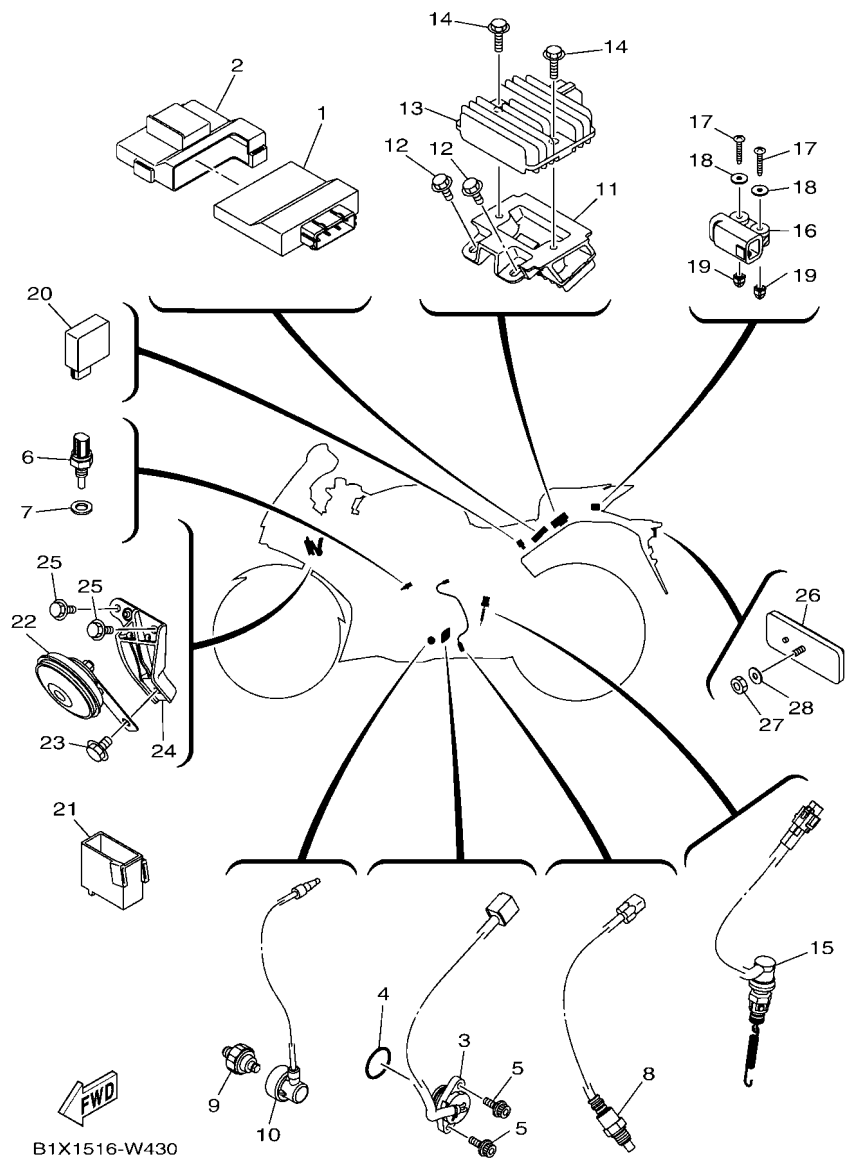


FIG. 42 ELECTRICAL 1

REF. NO.	PART NO.	DESCRIPTION	BFA1				REMARKS
28	90464-26001	CLAMP	1				
29	2D1-82589-02	PROTECTOR, WIRE HARNESS	1				

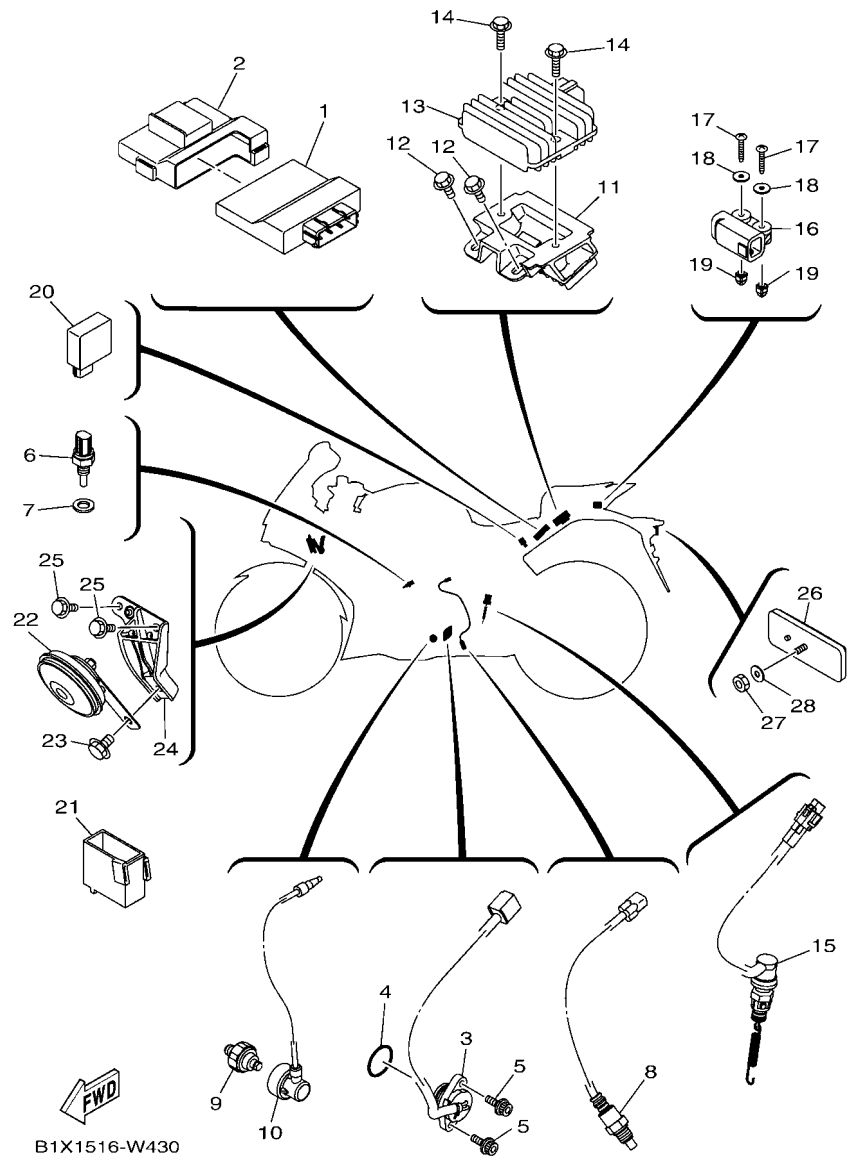
FIG. 43 ELECTRICAL 2



B1X1516-W430

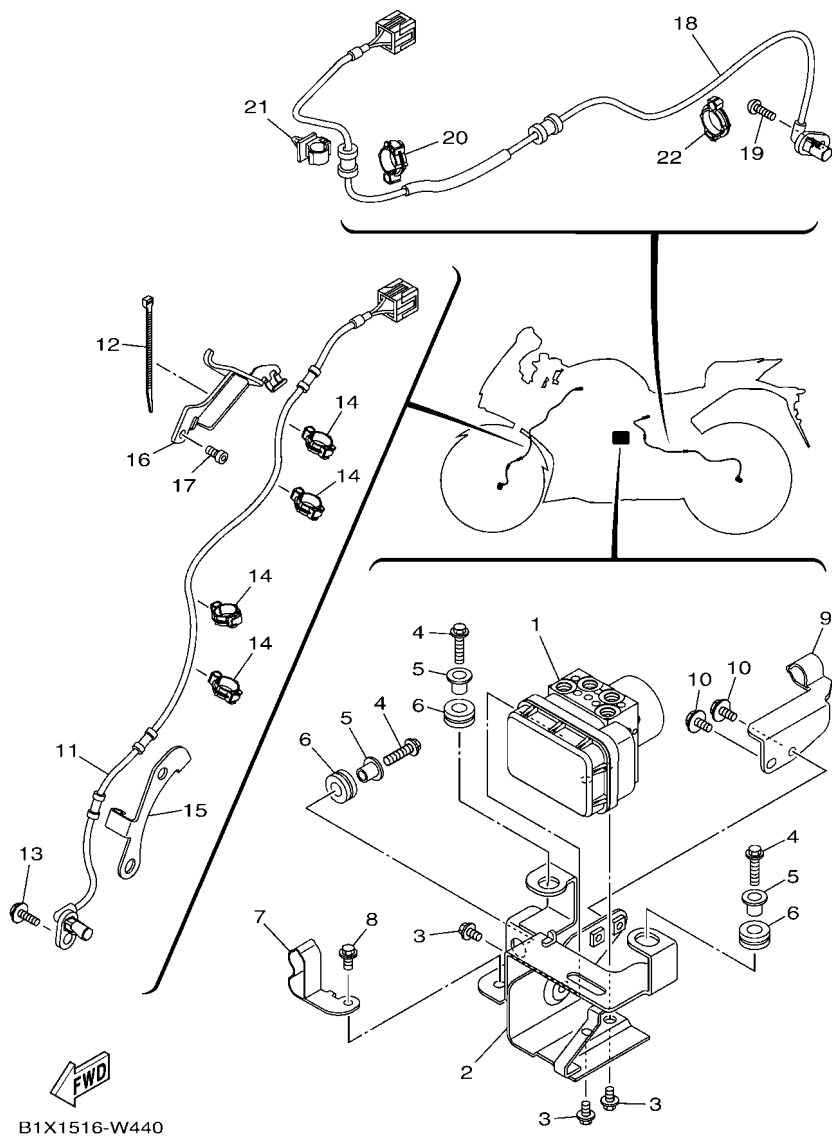
REF. NO.	PART NO.	DESCRIPTION	BFA1	REMARKS
1	B1X-H591A-20	ENGINE CONTROL UNIT ASSY	1	
2	B6W-H5546-00	BAND	1	
3	1WD-H2540-00	NEUTRAL SWITCH ASSY	1	
4	93210-21801	O-RING	1	
5	90110-05067	BOLT, HEXAGON SOCKET HEAD	2	
6	52B-H3591-00	THERMO UNIT	1	
7	90430-10804	GASKET	1	
8	B1X-H592A-00	SENSOR, OXYGEN	1	
9	1WS-82504-00	OIL PRESSURE SWITCH ASSY	1	
10	1WD-H1315-02	LEAD WIRE ASSY	1	
11	BR5-H1961-00	COVER	1	
12	95D02-06016	BOLT, FLANGE DEEP RECESS	2	
13	1WD-H1960-00	RECTIFIER & REGULATOR ASSY	1	
14	95D02-06025	BOLT, FLANGE DEEP RECESS	2	
15	1WD-H2530-10	STOP SWITCH ASSY	1	
16	1WD-H2576-01	SENSOR, LEAN ANGLE	1	
17	90160-04009	SCREW, ROUND TAPPING	2	
18	90201-04028	WASHER, PLATE	2	
19	4B4-84334-00	NUT, ADJUSTING	2	
20	B9T-83400-00	FLASHER CONT. UNIT ASSY	1	
21	B9T-H3836-00	BAND	1	
22	1WD-H3371-00	HORN	1	
23	95D07-08012	BOLT, FLANGE DEEP RECESS	1	
24	1WD-H3378-00	STAY, HORN	1	
25	95D07-06016	BOLT, FLANGE DEEP RECESS	2	
26	3C1-H5130-00	REAR REFLECTOR ASSY	1	
27	95602-05100	NUT, U	1	

FIG. 43 ELECTRICAL 2



REF. NO.	PART NO.	DESCRIPTION	BFA1				REMARKS
28	90201-05043	WASHER, PLATE	1				

**FIG. 44 ELECTRICAL 3**



REF. NO.	PART NO.	DESCRIPTION	BFA1	REMARKS
1	B6W-H5930-09	HYDRAULIC UNIT ASSY	1	
2	B1X-F175T-00	BRACKET 1	1	
3	95022-06010	BOLT, FLANGE	3	
4	95022-06025	BOLT, FLANGE	3	
5	90387-06M60	COLLAR	3	
6	90480-14229	GROMMET	3	
7	2WD-F5886-00	HOLDER, BRAKE HOSE	1	
8	95027-06012	BOLT, FLANGE	1	
9	2WD-F5875-00	HOLDER, BRAKE HOSE 1	1	
10	95027-06012	BOLT, FLANGE	2	
11	2WD-85970-01	WHEEL SENSOR ASSY, FRONT	1	
12	90464-22800	CLAMP	1	
13	95027-06016	BOLT, FLANGE	1	
14	90464-12013	CLAMP	4	
15	B5L-F3318-00	WIRE, HOLDER 1	1	
16	B6W-F3319-00	WIRE, HOLDER 2	1	
17	91317-06012	BOLT, HEXAGON SOCKET HEAD	1	
18	2WD-85980-01	WHEEL SENSOR ASSY, REAR	1	
19	92012-06016	BOLT, BUTTON HEAD	1	
20	90464-14803	CLAMP	1	
21	90464-10800	CLAMP	1	
22	90464-14803	CLAMP	1	

NUMERICAL INDEX

PART NO.	REF. NO.	PART NO.	REF. NO.	PART NO.	REF. NO.	PART NO.	REF. NO.	PART NO.	REF. NO.	PART NO.	REF. NO.
1WD-11413-00	2 - 23	1WD-16382-00	13 - 19	2WD-85970-01	44 - 11	5ST-E2462-00	6 - 12	1WD-E4728-00	9 - 6	1WD-E7241-00	14 - 19
1WD-11413-10	2 - 23	1WD-17424-00	14 - 28	2WD-85980-01	44 - 18	1WD-E2577-00	6 - 4	5TP-E4747-00	17 - 28	1WD-E7251-00	14 - 22
1WD-11413-20	2 - 23	278-17425-00	14 - 12	B1X-E1102-01	1 - 1	1WD-E2578-00	6 - 5		31 - 48	1WD-E7261-00	14 - 17
1WD-11413-30	2 - 23		14 - 29	1WD-E111G-00	1 - 15	1WD-E2671-00	6 - 10	1WD-E4758-00	9 - 3	1WD-E7402-00	14 - 13
1WD-11413-40	2 - 23	26P-21568-11	23 - 66		1 - 25	5YP-E2675-00	6 - 11	B1X-E475P-00	9 - 22	1WD-E7411-01	14 - 1
B1X-11416-00	2 - 10	1WD-22141-00	20 - 2	1WD-E1133-10	1 - 2	1WD-E2681-00	5 - 11	1WD-E4763-00	9 - 10	1WD-E7411-10	14 - 1
B1X-11416-10	2 - 10	3AH-22222-00	22 - 23	BS8-E1181-00	1 - 12	1WD-E319L-00	5 - 9	1WD-E4840-10	1 - 31	1WD-E7460-00	14 - 31
B1X-11416-20	2 - 10	31A-23125-31	22 - 8	B1X-E1191-00	1 - 16	B1X-E3300-00	7 - 1	1WD-E4881-00	1 - 32	1WD-E8101-00	16 - 4
B1X-11416-30	2 - 10		22 - 30	B1X-E1193-00	1 - 17	1WD-E3341-00	7 - 3	1WD-E4882-02	1 - 34	B1X-E8110-00	16 - 11
B1X-11416-40	2 - 10	31A-23149-31	22 - 7	B1X-E1195-00	1 - 18	1WD-E3342-00	7 - 4	1WD-E4890-00	1 - 20	1WD-E8111-00	16 - 12
1WD-11650-00	2 - 2		22 - 29	4YS-E1198-00	7 - 15	1WD-E3410-00	7 - 9	1WD-E4899-00	1 - 21	1WD-E8112-00	16 - 17
5SL-11654-00	2 - 3	3R4-23153-00	22 - 5	1WD-E1311-10	1 - 26	B1X-E3414-00	7 - 16	1WD-E5148-00	10 - 4	1EG-E8113-01	16 - 13
1WD-11656-00	2 - 5		22 - 27	B1X-E1351-00	1 - 27	1WD-E3415-00	7 - 10	B1X-E5150-00	10 - 1	1WD-E8115-00	16 - 14
1WD-11656-10	2 - 5	4V4-23188-L0	22 - 19	1WD-E1361-00	1 - 8	B1X-E3417-01	7 - 13	B1X-E5155-00	10 - 15	1WD-E8127-10	16 - 2
1WD-11656-20	2 - 5		22 - 36	1WD-E1411-10	2 - 1	1WD-E3440-10	7 - 11	1WD-E5362-00	5 - 18	1WD-E8140-01	16 - 8
1WD-11656-30	2 - 5	3FV-23462-00	22 - 38	1WD-E1454-00	2 - 22	54P-E3474-00	8 - 37	2MS-E5373-02	8 - 42	1WD-E8175-00	16 - 3
B1X-12121-10	3 - 2	3C1-24512-00	23 - 34	1WD-E1496-00	2 - 18	B1X-E3543-00	8 - 39	BS7-E5377-00	11 - 21	1WD-E8337-00	16 - 1
1HX-12168-F0	3 - 9	5YT-24665-00	34 - 24	1WD-E1531-00	2 - 15	1WD-E3556-00	8 - 6	1WD-E5411-00	11 - 1	1WD-E8511-00	15 - 4
1HX-12168-H1	3 - 9		34 - 29	1WD-E1536-00	2 - 6	1WD-E3573-00	8 - 15	1WD-E5413-10	11 - 16	1WD-E8512-00	15 - 5
1HX-12168-K1	3 - 9	1WD-25181-00	25 - 11	1WD-E1549-00	2 - 7	B1X-E3635-00	8 - 1	1WD-E5418-00	11 - 22	1WD-E8513-00	15 - 6
1HX-12168-M1	3 - 9	1WD-25381-00	27 - 21	BS8-E1603-00	2 - 12	B1X-E3750-01	8 - 3	B1X-E5421-00	5 - 1	1WD-E8531-00	15 - 7
1HX-12168-R1	3 - 9	5MT-25398-00	25 - 7	B1X-E1631-00	2 - 11	1WD-E3761-00	8 - 4	1WD-E5441-10	11 - 14	1WD-E8536-00	15 - 9
1HX-12168-U1	3 - 9		27 - 18	1WD-E1633-00	2 - 13	BS7-E3907-01	23 - 30	1WD-E5451-00	11 - 7	1WD-E8540-10	15 - 1
1HX-12168-W1	3 - 9	5MT-25398-10	25 - 7	B1X-E2111-00	3 - 1	3C1-E3915-00	23 - 31	1WD-E5461-00	11 - 10	5TP-E8542-00	15 - 2
1HX-12168-Y1	3 - 9		27 - 18	B1X-E2113-00	3 - 4	1WD-E3938-00	8 - 14	B1X-E5462-00	11 - 17	1WD-E8562-00	15 - 10
1HX-12169-11	3 - 9	5MT-25398-20	25 - 7	1WD-E2117-00	3 - 5	1WD-E3971-02	23 - 38	1WD-E5514-00	12 - 1	1WD-F1110-13	17 - 1
1HX-12169-31	3 - 9		27 - 18	3S0-E2118-00	3 - 6	54P-E416A-00	8 - 13	1WD-E5515-10	12 - 3	1WD-F112C-00	17 - 2
1HX-12169-50	3 - 9	1WD-25802-00	26 - 4	1PA-E2119-00	3 - 8	1WD-E4243-00	8 - 11	44D-E5521-00	12 - 2	B5L-F113J-00	18 - 7
1HX-12169-70	3 - 9	1WD-25802-50	28 - 4	BS8-E2119-00	3 - 7	BR5-E4411-00	8 - 23	1WD-E5580-00	12 - 4	B5L-F113K-01	18 - 8
1HX-12169-90	3 - 9	1WD-25803-00	26 - 5	1WD-E2126-00	3 - 3	B1X-E4412-00	8 - 27	1WD-E6111-00	13 - 1	2MS-F115R-00	23 - 56
1HX-12169-E0	3 - 9	1WD-25803-50	28 - 5	1WD-E2153-11	3 - 10	1WD-E4422-00	8 - 31	1WD-E6150-00	13 - 2	1WD-F1171-00	17 - 16
1HX-12169-G0	3 - 9	1WD-25805-00	26 - 12	B1X-E2170-00	4 - 1	BR5-E4437-00	8 - 26	1WD-E6154-00	13 - 3	1WD-F117G-00	17 - 3
1HX-12169-J0	3 - 9	1WD-25806-00	28 - 15	1WD-E2176-00	4 - 3	52B-E443E-00	8 - 35	1WD-E6181-00	13 - 13	1WD-F117K-00	24 - 12
1HX-12169-L0	3 - 9	5RB-25854-00	30 - 3	B1X-E2180-00	4 - 2	40D-E443G-00	27 - 30	1WD-E6324-00	13 - 6	BS7-F117V-00	34 - 19
1HX-12169-M0	3 - 9	36Y-2589H-00	30 - 5	1WD-E2213-00	4 - 9	1WD-E4451-00	8 - 34	1WD-E6331-00	13 - 5	BS7-F117W-00	34 - 21
1HX-12169-T0	3 - 9	5KN-25926-01	28 - 17	33S-E2223-00	5 - 7	1WD-E4452-00	8 - 28	1WD-E6333-10	13 - 8	B1X-F122A-00	17 - 22
B1X-12210-00	4 - 6	34X-25937-00	28 - 7	1WD-E2241-01	1 - 23	1WD-E4457-00	8 - 29	1WD-E6337-00	13 - 9	1WD-F122B-00	17 - 23
5PO-12411-01	6 - 1	4SS-27218-00	32 - 3	1WD-E2251-00	4 - 11	1WD-E4462-00	8 - 32	1WD-E6340-00	13 - 15	2MS-F134X-00	23 - 57
5NL-12564-00	1 - 28	3KW-27234-00	32 - 8	1WD-E2252-01	4 - 12	B1X-E4465-00	8 - 19	1WD-E6350-01	13 - 7	1WD-F135F-00	17 - 14
8GL-13571-00	8 - 16	4BP-27261-00	31 - 25	1WD-E2256-00	4 - 14	2MS-E4466-00	8 - 20	1WD-E6356-00	13 - 14	1WD-F144G-00	31 - 28
5JW-14104-00	8 - 9	B1X-82310-00	42 - 1	1WD-E2405-00	6 - 9	B1X-E4469-00	8 - 24	1WD-E6371-00	13 - 4	BS7-F1511-00-PA	18 - 1
8A7-14139-00	8 - 8	1WS-82504-00	43 - 9	1WD-E2413-00	6 - 2	B1X-E446C-00	8 - 25	1WD-E7121-00	14 - 7	BS7-F1511-00-PB	18 - 1
5PS-14147-00	8 - 5	2D1-82589-02	42 - 29	1WD-E2422-00	5 - 13	B1X-E4602-00	9 - 1	1WD-E7131-00	14 - 5	1WD-F153E-50	18 - 35
895-14169-00	8 - 7	B9T-83400-00	43 - 20	1WD-E2428-00	5 - 14	1WD-E4613-00	9 - 17	1WD-E7151-01	14 - 2	B5P-F1569-A0	18 - 36
1WS-14335-00	8 - 18	31A-83913-00	41 - 13	1WD-E2450-00	5 - 5	B1X-E4628-00	9 - 21	1WD-E7161-01	14 - 6	B5P-F1569-C0	18 - 36
8HG-14534-00	8 - 17	31A-83945-00	41 - 12	1WD-E2453-00	5 - 6	BR5-E4710-00	9 - 2	1WD-E7211-00	14 - 23	BR5-F1611-01	18 - 13
5VY-1482K-00	1 - 19	4B4-84334-00	43 - 19	33S-E2456-00	5 - 8	54D-E4714-00	9 - 11	1WD-E7221-00	14 - 14	1WD-F1617-01	18 - 21
2H7-15361-00	5 - 17	1WS-85801-01	8 - 12	1WD-E2461-00	6 - 8	1WD-E4715-00	9 - 12	1WD-E7231-00	14 - 18	1WD-F1621-01	18 - 31

NUMERICAL INDEX

PART NO.	REF. NO.	PART NO.	REF. NO.	PART NO.	REF. NO.	PART NO.	REF. NO.	PART NO.	REF. NO.	PART NO.	REF. NO.
B1X-F1629-00	18 - 20	B5L-F3103-00	22 - 20	BS7-F41B1-00-P7	23 - 20	2WD-F581K-00	32 - 22	2DP-F6240-00	29 - 10	BS7-F836N-00	33 - 15
1WD-F163A-00	18 - 33	BS7-F3110-00	22 - 3	B5L-F4244-00	23 - 68	1WD-F581U-01	26 - 1	2DP-F6241-00	29 - 9	BS7-F836R-00	33 - 19
BR5-F163E-01	18 - 18	BS7-F3111-00	22 - 18	B5L-F4245-00	23 - 69	50C-F582A-50	32 - 5	1WD-F6246-00	29 - 14	1WD-F8376-00	33 - 13
1WD-F1652-00	17 - 4		22 - 35	1WD-F4312-01	23 - 39	B04-F582E-00	32 - 21	1S7-F6257-00	29 - 13	44D-F8379-00	34 - 9
B17-F1668-00	20 - 17	BK6-F3117-00	22 - 15	B9T-F4314-00	23 - 40	2WD-F582J-00	32 - 25	BS7-F6280-00	33 - 25		34 - 18
1WD-F1669-00	18 - 14	BS7-F3118-00	22 - 16	2MS-F4314-01	23 - 44	1WD-F582W-00	28 - 1	BS7-F6290-00	33 - 26	BS7-F837V-00	34 - 53
1WD-F1688-00	18 - 26	B5L-F3120-00	22 - 21	2MS-F4315-00	23 - 51	5TL-F5838-00	28 - 18	B1X-F6301-00	29 - 18	BS7-F837W-00	34 - 56
1WD-F1689-00	18 - 27	BS7-F3126-10	22 - 10	B1X-F4316-00	23 - 60	1WD-F5852-00	30 - 4	1WD-F6335-00	29 - 16	BS7-F8381-00	33 - 1
1WD-F16A2-00	18 - 17		22 - 32	B1X-F4317-00	23 - 62	1WD-F5852-50	32 - 12	1WD-F7211-00	31 - 24	BS7-F8385-00-P2	34 - 33
1WD-F1711-00-P1	19 - 1	BS7-F3141-00	22 - 14	1WD-F4376-00	23 - 42	2VN-F5854-00	32 - 10	50C-F7222-00	32 - 4	BS7-F8385-00-P9	34 - 33
1WD-F1711-00-P4	19 - 1		22 - 24	B1X-F4421-00	23 - 64	3C1-F5855-00	30 - 7	BS8-F7261-00	16 - 18	BS7-F838N-00	39 - 8
BS7-F171A-01-P0	23 - 28	B48-F3144-00	22 - 4	3C1-F4486-00	23 - 36	50C-F5855-00	32 - 11	1WD-F7311-00	31 - 1	B5P-F8391-00	33 - 33
BS7-F171A-01-P7	23 - 28		22 - 26	BS7-F4491-00	23 - 35	50C-F5866-00	32 - 6	1WD-F7321-10	31 - 2	B5L-F8391-20	33 - 33
BS7-F171E-00	19 - 36	BK6-F3145-00	22 - 6	3C1-F4519-00	23 - 33	3RW-F5867-00	30 - 6	1WD-F7430-01	31 - 32	B5L-F8392-30	33 - 34
1WD-F171L-00	19 - 16		22 - 28	1WD-F4710-02	24 - 1	1WD-F5870-00	30 - 1	1WD-F7431-01	31 - 33	B5P-F8393-00	34 - 59
1WD-F171M-00	19 - 19	2BU-F3158-00	22 - 12	1WD-F4711-01	24 - 2	B5L-F5872-00	30 - 18	1WD-F7435-00	31 - 11	B5L-F8393-40	34 - 60
1WD-F171N-00	19 - 22	BS7-F3170-00	22 - 11	3C1-F4741-00	24 - 6	2WD-F5873-00	30 - 31		31 - 20	B5L-F8394-40	34 - 61
BS7-F171X-00	19 - 41	BK6-F3171-00	22 - 9	5BP-F4741-00	24 - 3	B5L-F5874-00	30 - 34	1WD-F7437-00	31 - 36	B1X-F8395-00-P2	34 - 39
1WD-F1721-00-P1	19 - 8		22 - 31	1WD-F4750-01	24 - 5	2WD-F5875-00	44 - 9		31 - 44	B1X-F8395-00-P3	34 - 39
1WD-F1721-00-P4	19 - 8	31B-F3181-00	22 - 13	1WD-F4780-00	24 - 7	B5L-F587A-00	30 - 28	1WD-F7440-01	31 - 40	B5P-F8398-00	34 - 62
BS7-F172G-00-P0	34 - 1	BK6-F319U-00	22 - 25	1WD-F478E-00	24 - 10	2WD-F5886-00	44 - 7	1WD-F7441-01	31 - 41	B5P-F8399-00	34 - 63
BS7-F172G-00-P5	34 - 1	BK6-F330G-00	22 - 22	1WD-F4792-00	24 - 8	2WD-F5887-00	32 - 28	1WD-F7442-01	31 - 9	BS7-F8415-00	34 - 10
BS7-F172H-00-P0	34 - 11	B5L-F3318-00	44 - 15	2MS-F483H-00	23 - 55	B6W-F5887-00	30 - 26	1WD-F7443-00	31 - 18		34 - 17
BS7-F172H-00-P5	34 - 11	B6W-F3319-00	44 - 16	1WD-F510C-01	25 - 2	2WD-F588F-00	30 - 16	1WD-F7445-00	31 - 15	BK6-F8483-00	33 - 27
BS7-F172W-00	19 - 31	BK6-F332K-00	22 - 33	BS7-F5168-10-98	25 - 1	2WD-F588G-01	30 - 37	1WD-F7446-00	31 - 31	BS7-F8484-00	33 - 28
1WD-F1731-00-P1	19 - 34	BS7-F3340-00	22 - 37	BS7-F5168-10-P0	25 - 1	50C-F5894-10	32 - 9	1WD-F7451-00	31 - 10	BS7-F8485-00	33 - 29
1WD-F1731-00-P5	19 - 34	BK6-F3357-00	22 - 17	2DP-F517G-00	25 - 8	1WD-F5895-50	32 - 13	1WD-F7461-00	31 - 19	1WD-H1315-02	43 - 10
1WD-F1732-00	40 - 7	BK6-F3393-00	22 - 34		27 - 19	50C-F589A-00	32 - 15	B9T-F8100-00	24 - 15	BS7-H1410-00	35 - 2
B5L-F173E-00	19 - 47	5BP-F3416-10	21 - 2	BS7-F5338-10-98	27 - 1	1WD-F5914-50	28 - 16	31B-F8307-00	19 - 15	BR5-H1450-00	35 - 1
B5L-F173F-00	19 - 48	5BP-F3418-00	21 - 5	BS7-F5338-10-P0	27 - 1	5YP-F5917-00	26 - 8		23 - 29	1WD-H1800-01	36 - 1
B1X-F175T-00	44 - 2	BS7-F3435-00	21 - 6	1WD-F5364-00	27 - 5		28 - 6		33 - 11	B74-H1801-00	36 - 2
1WD-F1816-02	19 - 28	20P-F3469-00	29 - 4	1WD-F5366-01-98	27 - 6	1WD-F5919-00	26 - 10	BS7-F8327-00	33 - 18	1WD-H1828-00	36 - 4
1WD-F1817-01	19 - 29		29 - 8	1WD-F5366-01-P0	27 - 6	1WD-F5919-50	28 - 9		33 - 22	4FP-H182L-00	36 - 6
3C1-F1828-00	19 - 27	BS7-F3818-00	30 - 24	1WD-F5377-00	27 - 9	2WD-F5921-50	28 - 12	1WD-F8328-60	34 - 64	1WD-H183G-00	36 - 5
1WD-F1871-01	19 - 24	BS7-F4110-00	23 - 1	1WD-F537W-00	27 - 11	5YP-F5924-00	26 - 11	1WD-F8328-A0	34 - 64	1WD-H1861-00	36 - 3
1WD-F1875-01	19 - 26	BS7-F412Y-00	23 - 6	1WD-F537X-00	27 - 12	1WD-F5924-50	28 - 10	BS7-F833E-00	34 - 45	1WD-H1940-00	42 - 10
1WD-F191B-00	17 - 8	1WD-F413B-01	23 - 67	1WD-F5383-00	27 - 23	5YP-F5925-01	26 - 9	BS7-F8351-00-P0	33 - 7	1WD-H1950-00	42 - 9
1WD-F193A-00	17 - 5	1WD-F414E-00	33 - 12	1PA-F5386-00	25 - 10		28 - 11	BS7-F8351-00-P8	33 - 7	1WD-H1960-00	43 - 13
1WD-F2110-00	20 - 1	BS7-F414E-00	23 - 5	1WD-F5386-00	27 - 22	5YP-F5937-00	26 - 7	BS7-F8356-00	33 - 23	BR5-H1961-00	43 - 11
1WD-F2129-01	20 - 3	5D9-F414G-00	17 - 6	1WD-F5388-00	27 - 26	1WD-F5939-51	28 - 13	BS7-F835G-00	33 - 3	2YD-H2100-00	42 - 2
1WD-F2151-00	20 - 7	2MS-F4170-00	23 - 53	1WD-F539F-00	27 - 13	1WD-F5939-61	28 - 14	BS7-F835U-00-P2	34 - 23	2WD-H2115-01	42 - 14
1WD-F2174-00	27 - 27	1DW-F4180-02	23 - 46	1WD-F5443-00	27 - 10	BS7-F6121-00	29 - 1	BS7-F835U-00-P9	34 - 23	B6W-H2116-00	42 - 15
1WD-F2184-00	20 - 4	BS7-F4188-00	23 - 2	1WD-F5807-00	30 - 2	BS7-F6122-00	29 - 5	BS7-F835V-00-P2	34 - 28	1WD-H2121-00	42 - 3
BS7-F2210-00	20 - 14	BS7-F4191-10	23 - 11	1WD-F5808-00	32 - 2	B5L-F612E-00	30 - 23	BS7-F835V-00-P9	34 - 28	5D9-H2126-00	23 - 3
1WD-F2311-01	20 - 11	B1X-F419A-00	23 - 65	1WD-F580E-00	32 - 1	BS7-F612N-00	17 - 29	B17-F836B-30	19 - 46	1WD-H2131-00	42 - 4
1WD-F248B-00	20 - 9	B1X-F419E-00	23 - 54	1WD-F580U-01	26 - 3	BS7-F6131-00	29 - 17	BS7-F836K-00	34 - 47	5TL-H2131-00	24 - 16
B5L-F3100-00	22 - 1	B1X-F419F-00	23 - 48	2WD-F580W-00	28 - 3	1S7-F622F-00	29 - 12	BS7-F836L-00	34 - 49	1WD-H2151-01	42 - 11
BS7-F3102-00	22 - 2	BS7-F41B1-00-P0	23 - 20	B1X-F581J-00	30 - 22	2MS-F622H-00	29 - 11	B1X-F836M-00	34 - 51	1WD-H2151-10	42 - 7

NUMERICAL INDEX

PART NO.	REF. NO.	PART NO.	REF. NO.	PART NO.	REF. NO.	PART NO.	REF. NO.	PART NO.	REF. NO.	PART NO.	REF. NO.
1WD-H2151-20	42 - 6	B1X-H592A-00	43 - 8	90111-05003	33 - 17	90183-05807	19 - 10	90215-18800	13 - 10	90387-06899	23 - 23
1WD-H2151-30	42 - 8	B6W-H5930-09	44 - 1		33 - 21		33 - 9	90240-08124	32 - 16		34 - 3
1WD-H2155-00	42 - 12	4C9-W0048-00	26 - 6	90111-05018	18 - 25		34 - 26	90240-08145	31 - 13		34 - 13
B1X-H2501-00	42 - 21	5YP-W0048-50	28 - 8	90111-05021	18 - 22		34 - 31		31 - 22		34 - 35
1WD-H2511-09	42 - 22	BS7-WF461-00	23 - 16	90111-06013	31 - 16		34 - 37		31 - 37		34 - 41
1WD-H2530-10	43 - 15	1WD-WF479-00	24 - 11	90111-06117	34 - 36		34 - 43		31 - 45	90387-068L9	18 - 29
1WD-H2540-00	43 - 3	B1X-XH250-00	42 - 24		34 - 42		39 - 9	90269-05005	39 - 11	90387-068M3	23 - 8
1WD-H2566-01	42 - 25	90105-06027	1 - 3		40 - 2		40 - 5	90269-05008	17 - 30	90387-068N4	9 - 14
1WD-H2576-01	43 - 16		7 - 8	90111-06119	20 - 13	90183-05M02	34 - 38		23 - 47	90387-068S8	23 - 13
B1X-H2590-00	42 - 5	90105-07800	4 - 4	90111-06121	32 - 20		34 - 44	90269-06816	18 - 19	90387-06M60	44 - 5
1WD-H2591-00	42 - 27	90105-088F7	10 - 6	90111-06137	18 - 2	90183-06011	9 - 16		18 - 34	90387-07819	17 - 18
BR5-H2592-00	42 - 16	90105-088F8	2 - 16	90111-06802	9 - 4	90183-06818	9 - 5		19 - 2	90387-08813	17 - 27
1WD-H2910-00	41 - 9	90105-088G0	10 - 7	90111-06847	9 - 9	90201-04028	43 - 18		19 - 9		31 - 49
1WD-H2911-00	41 - 10	90105-088G7	9 - 19		18 - 5	90201-04804	40 - 14		19 - 18	90387-10010	31 - 6
5BP-H2917-00	41 - 16	90105-106A7	31 - 5	90111-06860	9 - 23	90201-05036	39 - 6		19 - 21	90387-17810	27 - 2
B1X-H330A-00	37 - 1	90105-10883	2 - 8	90111-08087	26 - 2	90201-05043	43 - 28		23 - 27	90387-20814	14 - 24
	37 - 2		35 - 4		28 - 2	90201-05827	38 - 8		23 - 59	90388-10816	17 - 7
B1X-H330A-10	37 - 5	90105-10889	17 - 11	90116-10065	27 - 14	90201-06072	6 - 14		30 - 25	90401-10812	30 - 19
B1X-H330B-00	37 - 6	90105-10891	17 - 12	90119-06309	23 - 24	90201-06088	9 - 15		33 - 16		30 - 29
B1X-H3318-00	37 - 4	90105-12093	20 - 15	90119-06810	19 - 7	90201-06380	34 - 6		33 - 20		30 - 32
1WD-H3371-00	43 - 22	90105-12309	20 - 8		19 - 14	90201-08083	32 - 17		34 - 55		30 - 35
1WD-H3378-00	43 - 24	90105-14102	21 - 7		34 - 4	90201-08612	9 - 20		34 - 58		32 - 23
B1X-H338V-00	37 - 3	90109-05003	18 - 32		34 - 14	90201-10021	16 - 20	90269-07007	17 - 31		32 - 26
B1X-H3500-01	38 - 1	90109-060G4	42 - 23	90123-08083	41 - 18		31 - 26	90280-05013	35 - 6	90401-20011	7 - 12
B1X-H3519-00	38 - 5	90109-063F1	18 - 15	90149-05029	25 - 9	90201-10118	30 - 20	90282-04036	2 - 17	90413-06031	8 - 21
B5P-H3571-01	38 - 2	90109-06577	30 - 10		27 - 20		30 - 30	90338-05010	33 - 32	90430-06014	4 - 8
BS7-H3572-01	38 - 3	90109-06898	1 - 14	90149-10044	26 - 13		30 - 33	90338-06018	19 - 37		5 - 15
52B-H3591-00	43 - 6	90109-06899	1 - 24	90150-05023	33 - 8		30 - 36		19 - 42		10 - 12
B9T-H3836-00	43 - 21	90109-068B2	23 - 25	90151-03005	41 - 17		32 - 24	90338-09803	30 - 14	90430-08119	1 - 6
1WD-H3912-00	41 - 11	90109-085G6	31 - 17	90159-06054	24 - 13		32 - 27		41 - 21	90430-08143	11 - 4
1WD-H3922-00	30 - 8		31 - 30	90160-04009	43 - 17	90201-10119	7 - 6	90338-16262	10 - 2	90430-10804	43 - 7
3AY-H3936-00	41 - 1	90110-05032	11 - 2	90160-05810	19 - 35	90201-10843	13 - 16	90338-23801	17 - 15	90445-217G3	31 - 8
BS7-H3972-00	41 - 3	90110-05067	43 - 5	90170-06023	16 - 15	90201-10845	1 - 9	90340-12808	7 - 14	90450-28001	6 - 7
B1X-H3975-01	41 - 5	90110-05806	23 - 17	90170-18221	13 - 11	90201-10848	2 - 9	90340-18002	1 - 4	90450-52801	8 - 2
2DP-H3980-01	30 - 11	90110-05809	42 - 26	90176-06065	30 - 27		35 - 5	90340-27008	10 - 13	90462-08225	5 - 20
BS7-H4300-00	39 - 1	90110-06161	4 - 13	90179-05849	33 - 2	90201-10854	17 - 10	90340-32819	11 - 5	90462-08806	11 - 20
BS7-H4300-10	39 - 2		4 - 15	90179-07652	2 - 4	90201-127E1	16 - 7	90387-05042	40 - 16	90462-08810	7 - 18
BS7-H4547-00	40 - 10		10 - 16	90179-08316	41 - 19	90201-16812	2 - 19	90387-06131	33 - 31	90462-08819	11 - 19
1WD-H4710-02	40 - 1		12 - 5	90179-10805	17 - 13	90201-17809	27 - 25	90387-06242	20 - 12	90464-10800	44 - 21
1WD-H4726-00	40 - 11	90110-06177	35 - 3	90179-20013	14 - 33	90201-20023	14 - 32	90387-06273	9 - 8	90464-12013	44 - 14
BS7-H4740-10	40 - 8	90110-06178	11 - 15	90179-25615	21 - 3	90201-20276	14 - 25	90387-064W3	6 - 15	90464-12015	17 - 21
1WD-H4744-00	40 - 9	90110-06182	15 - 11	90183-05076	18 - 16	90201-22013	13 - 12	90387-066J9	18 - 28	90464-13227	41 - 22
1WD-H4753-00	40 - 12	90110-06870	1 - 10	90183-050A7	18 - 23	90202-05088	33 - 14	90387-067V1	40 - 3	90464-14803	44 - 20
2FC-H5111-00	18 - 11	90110-08071	31 - 39		19 - 4	90202-26142	21 - 4	90387-06857	19 - 25		44 - 22
3C1-H5130-00	43 - 26		31 - 47		19 - 11	90206-14001	16 - 19	90387-06899	18 - 4	90464-15014	23 - 49
B6W-H5546-00	43 - 2	90111-05003	19 - 32		34 - 8	90209-25011	14 - 15		18 - 10	90464-16012	23 - 43
BS7-H5752-00	23 - 32		19 - 38		34 - 16	90214-22008	14 - 3		19 - 6	90464-22800	41 - 23
B1X-H591A-20	43 - 1		19 - 43	90183-05807	19 - 3		14 - 20		19 - 13		42 - 19



NUMERICAL INDEX

PART NO.	REF. NO.	PART NO.	REF. NO.	PART NO.	REF. NO.	PART NO.	REF. NO.	PART NO.	REF. NO.	PART NO.	REF. NO.
90464-22800	44 - 12	90480-15808	6 - 16	92014-08012	11 - 3	95022-06008	4 - 7	95707-08500	9 - 18	98502-06012	8 - 10
90464-26001	42 - 28	90480-18813	23 - 7	92902-08600	13 - 20	95022-06010	44 - 3	95802-06010	31 - 29	98507-04025	41 - 4
90464-30001	41 - 8	90501-06022	15 - 3			95022-06012	24 - 4	95812-06012	30 - 15	98507-04030	41 - 6
90464-30009	17 - 20	90501-080A2	15 - 8	92907-10600	17 - 26		34 - 46	95812-06020	4 - 10	98902-05020	8 - 33
	32 - 30	90501-12743	31 - 34	93101-20802	14 - 11		38 - 9	95812-06035	10 - 8	99002-07600	13 - 21
90464-36005	41 - 2		31 - 42		14 - 27	95022-06014	17 - 19	95812-06045	10 - 9	99009-08400	5 - 10
90464-36800	42 - 17	90501-22800	2 - 20	93102-12891	16 - 10	95022-06020	6 - 3	95812-06065	10 - 10	99009-10400	7 - 5
90464-70800	42 - 18	90506-23812	31 - 4	93102-15801	5 - 4		30 - 17	95812-08035	33 - 24		13 - 17
	42 - 20	90506-26807	31 - 27	93102-35808	14 - 30		30 - 21	95812-08070	10 - 11	99009-12400	16 - 6
90467-08003	19 - 30	90508-18136	13 - 18	93106-23002	27 - 4	95022-06025	5 - 16	95817-06012	23 - 10	99009-15500	7 - 2
90467-09006	8 - 22	90508-183B9	31 - 12	93106-26815	25 - 3		7 - 17	95817-10025	31 - 3	99530-08012	7 - 7
	23 - 45		31 - 21	93106-38046	27 - 8		11 - 9	95827-06025	6 - 13		11 - 8
	23 - 52	90508-29806	16 - 5	93210-068F7	10 - 17		11 - 12	95D02-06016	43 - 12		11 - 11
	23 - 61	90520-02843	23 - 4	93210-108H5	41 - 14		11 - 18	95D02-06025	43 - 14	99530-10014	10 - 5
90467-11009	23 - 63	90520-03841	23 - 21	93210-12803	10 - 3		11 - 23	95D07-06016	43 - 25	99530-14016	1 - 13
90467-110A3	8 - 36	90520-07808	33 - 6	93210-15620	32 - 7		36 - 7	95D07-08012	43 - 23		1 - 30
90467-12052	8 - 41		33 - 10	93210-16716	1 - 29		44 - 4	95D32-06010	8 - 38		
90467-12085	32 - 14	90520-10850	19 - 40	93210-21801	43 - 4	95022-06050	11 - 13	95D37-06014	32 - 29		
90467-13802	8 - 40		19 - 45	93210-27807	5 - 19	95022-08012	1 - 5	97012-06020	16 - 21		
	8 - 43	90520-20825	39 - 4	93210-32172	10 - 14	95022-08014	23 - 15	97022-06030	23 - 9		
90467-15012	23 - 41	90520-30805	19 - 39	93210-32816	11 - 6	95027-06012	30 - 38		23 - 14		
90467-16800	1 - 36		19 - 44	93306-20314	27 - 3		30 - 39	97507-06525	41 - 20		
90467-16801	1 - 33	90560-06244	19 - 33	93306-255Y9	14 - 8		44 - 8	97602-04212	30 - 12		
	1 - 35	91312-05008	42 - 13	93306-302X4	25 - 4		44 - 10	97607-05220	41 - 7		
90467-250A1	6 - 6	91312-05010	23 - 18	93306-30450	27 - 7	95027-06016	23 - 58	97702-50016	24 - 14		
90480-01559	23 - 26		23 - 37	93311-420Y3	14 - 10		44 - 13		33 - 4		
90480-01806	23 - 19		29 - 19		14 - 26	95027-06025	30 - 13		34 - 7		
90480-01821	34 - 27	91312-06010	5 - 12	93315-21570	5 - 3	95027-08012	23 - 50		34 - 15		
	34 - 32	91312-10040	22 - 40	93317-11096	5 - 2	95027-08035	9 - 13		34 - 20		
90480-10003	40 - 6	91317-06012	44 - 17	93317-11295	16 - 9	95302-06600	16 - 16		34 - 22		
90480-11009	40 - 15	91317-06016	29 - 3	93320-32403	20 - 5	95302-08600	27 - 29		34 - 25		
90480-12581	9 - 7		29 - 7	93399-99932	22 - 39	95602-05100	43 - 27		34 - 30		
90480-12808	18 - 3	91317-06020	29 - 15	93399-999Y3	21 - 1	95602-06100	30 - 9		34 - 54		
	18 - 9	91317-06030	33 - 30	93440-24200	14 - 4		41 - 15		34 - 57		
	19 - 5	91317-08020	29 - 2		14 - 21	95602-06200	18 - 30		38 - 7		
	19 - 12		29 - 6	93440-28184	14 - 16	95602-10200	27 - 15		39 - 3		
	23 - 22	91317-08030	21 - 8	93440-52009	14 - 9		31 - 7		39 - 7		
	34 - 2	91317-10020	17 - 24	93450-16068	2 - 14	95602-12100	20 - 10		39 - 10		
	34 - 12	91317-10045	17 - 25	93501-04830	31 - 35		20 - 16	97702-50025	8 - 30		
	34 - 34	91317-10060	17 - 9		31 - 43	95602-14200	20 - 6	97707-30020	38 - 4		
	34 - 40	91332-06020	1 - 22	93605-10090	2 - 21		25 - 12	97707-40020	40 - 13		
90480-13001	40 - 4	91401-20012	32 - 18	93900-00828	25 - 6	95602-16200	27 - 24	97707-50016	18 - 24		
90480-13398	17 - 17	91401-25015	31 - 14		27 - 17	95607-08200	9 - 24		19 - 17		
	33 - 5		31 - 23	94111-17801	25 - 5	95612-08625	1 - 7		19 - 20		
90480-14229	38 - 6		31 - 38	94114-17802	27 - 16	95702-05500	18 - 12		19 - 23		
	39 - 5		31 - 46	94568-H3112	27 - 31	95702-06500	18 - 6		34 - 48		
	44 - 6	92012-06016	44 - 19	94568-K0118	4 - 5		34 - 5		34 - 50		
90480-15807	23 - 12	92012-08030	32 - 19	94700-00436	1 - 11	95707-06500	24 - 9		34 - 52		